

**Framing**

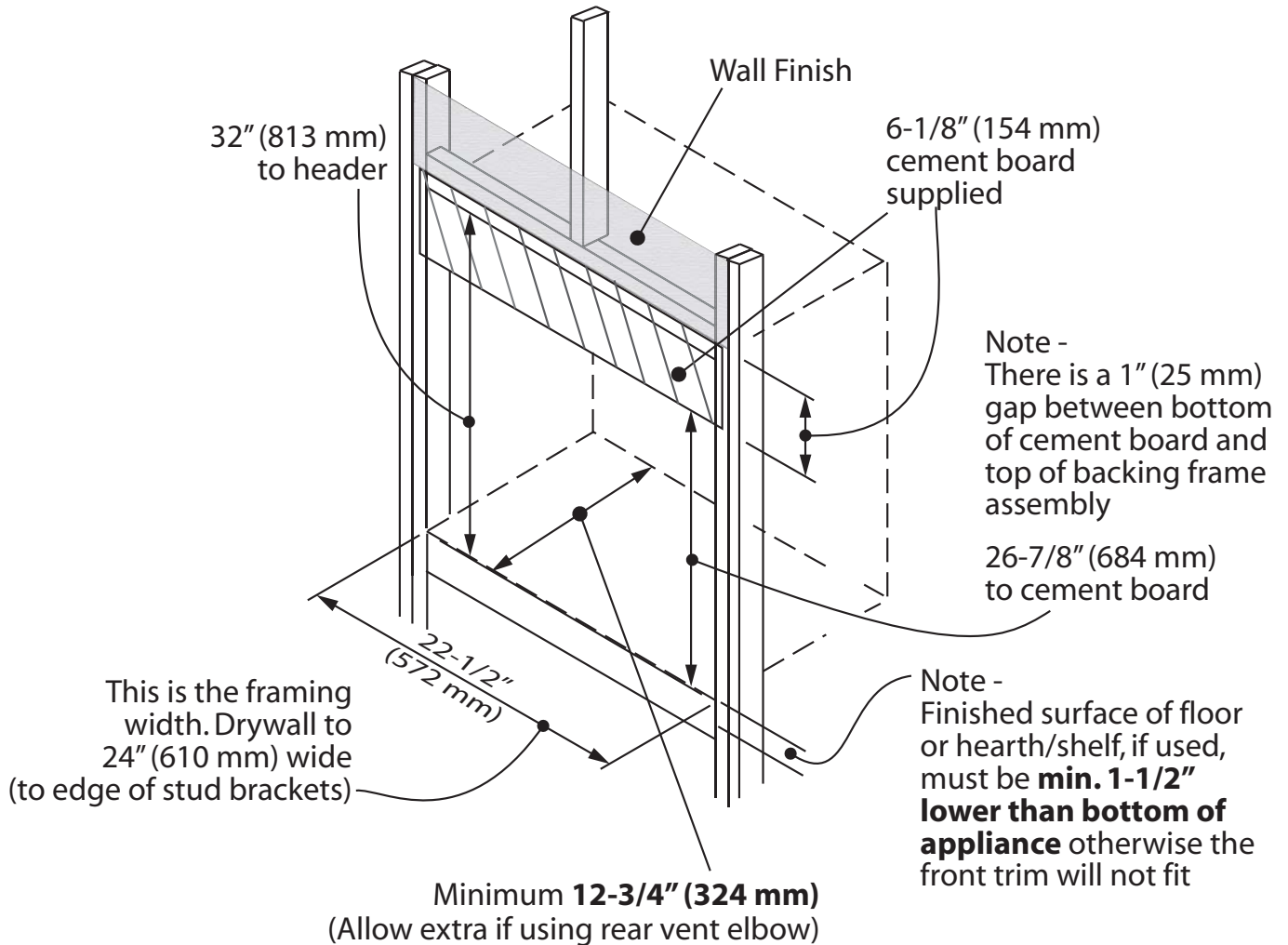

## Wall Finish

### Adjustability of the Ledgeview Front ZC

- **Method 1.** The appliance's position within the framing cavity may be adjusted forward in the framing up to 1" to accommodate additional wall finish thickness "tucked" behind the backing plate.
- **Method 2.** The Backing Plate is also adjustable to accommodate up to an additional 3/4" of tile or other non-combustible material over top of the 1/2" non-combustible wall board.
- Method 1 and Method 2 may be combined for a total of 1-3/4" of non-combustible material over top of the 1/2" wall board.

**Attention!** When positioning the appliance forward of the framing cavity (Method 1), ensure that the front edge of the backing frame does not protrude beyond the planned finished wall surface. Otherwise the backing plate, when installed, will not sit against the finished wall.

