

# Installation Manual



# LX2

Direct Vent Zero Clearance  
Gas Fireplace  
natural gas 2200LKN / 2200RKN  
propane gas 2200LKP / 2200RKP  
**CORNER**

Installer: Place model/serial number here.

Installer: Leave this manual with the appliance.  
Consumer: Retain this manual for future reference.

**⚠ WARNING:**  
**FIRE OR EXPLOSION HAZARD**  
Failure to follow safety warnings exactly could result in serious injury, death, or property damage.

Do not store or use gasoline or other flammable vapors and liquids in the vicinity of this or any other appliance.

#### WHAT TO DO IF YOU SMELL GAS

- Do not try to light any appliance.

- Do not touch any electrical switch; do not use any phone in your building.
- Leave the building immediately.
- Immediately call your gas supplier from a neighbor's phone. Follow the gas supplier's instructions.
- If you cannot reach your gas supplier, call the fire department.

Installation and service must be performed by a qualified installer, service agency or the gas supplier.

## **⚠ DANGER**



Hot glass will cause burns.

Do not touch glass until cooled.

Never allow children to touch glass.

A barrier designed to reduce the risk of burns from the hot viewing glass is provided with this appliance and must be installed for the protection of children and other at-risk individuals.

This appliance may be installed in an after-market permanently located, manufactured (mobile) home where not prohibited by local codes. This appliance is only for use with the type of gas indicated on the rating plate. This appliance is not convertible for use with other gases, unless a certified kit is used.

**INSTALLER:** Leave this manual with the appliance.

**CONSUMER:** Retain this manual for future reference.

#### Massachusetts:

The piping and final gas connection must be performed by a licensed plumber or gas fitter in the State of Massachusetts. Also, see Carbon Monoxide Detector requirements in the fireplace installation manual.

#### **⚠ WARNING**

This product can expose you to chemicals including Benzene, which is known to the State of California to cause cancer and birth defects or other reproductive harm. For more information go to [www.P65Warnings.ca.gov](http://www.P65Warnings.ca.gov).

Note: Natural gas, in its original state, contains Benzene.

This appliance is a domestic room-heating appliance. It must not be used for any other purposes such as drying clothes, etc.

This appliance is suitable for installation in a bedroom or bed sitting room.

Ce guide est disponible en français sur demande.



We recommend a US Certified National Fireplace Institute (NFI) specialist install our gas hearth products.



The information contained in this manual is believed to be correct at the time of printing. Miles Industries Ltd. reserves the right to change or modify any information or specifications without notice. Miles Industries Ltd. grants no warranty, implied or stated, for the installation or maintenance of your heater, and assumes no responsibility for any consequential damage(s).

© Copyright Miles Industries Ltd., 2021. All rights reserved.  
Designed and manufactured for Miles Industries Ltd.

# Welcome to Valor®

This appliance has been professionally installed by:

Dealer Name: \_\_\_\_\_

Phone: \_\_\_\_\_

<b>Fireplace Safety</b> .....	<b>4</b>
<b>Specifications</b> .....	<b>6</b>
<b>Kits &amp; Accessories</b> .....	<b>7</b>
<b>Dimensions &amp; Location</b> .....	<b>8</b>
<b>Planning</b> .....	<b>9</b>
Overview .....	10
Clearances—Combustible Projections .....	11
Clearances—Alcove .....	12
Minimum Vertical Vent—6-5/8" Vent.....	13
Minimum Vertical Vent—8" Vent.....	14
Framing—Minimal .....	15
Framing—Extended.....	16
Wall Finish .....	17
<b>Venting</b> .....	<b>19</b>
Overview .....	19
Typical Components .....	20
Venting Chart—4" x 6-5/8".....	21
Venting Chart—5" x 8" .....	22
Restrictors.....	23
Wall Termination .....	24
Roof Termination .....	25
<b>Preparation</b> .....	<b>26</b>
Window Sill & Window.....	26
Standoffs & Adapter .....	27

**Please read this manual BEFORE installing and operating this appliance.**

<b>Installation</b> .....	<b>28</b>
Electrical Wiring.....	28
Gas Supply.....	29
Remote Battery & Wall Switch Kit .....	31
WiFi Module (optional) .....	33
Liners .....	34
Fuel Beds .....	36
Birch Log Kit 1700BLK.....	36
Long Beach Driftwood 1705DWK.....	39
Decorative Glass Murano 2200DGM .....	42
Decorative Glass Set 2200DGS .....	43
Splitwood Kit 1700SWK.....	44
Rocks & Shale Set 1714RSS.....	49
Replacing Light Bulbs .....	51
Window Re-Installation.....	52
Remote Control Set-Up .....	54
Check Operation .....	56
Barrier Screen & Window Sill .....	57
<b>Wiring Diagram</b> .....	<b>58</b>
<b>Approved Venting Components</b> .....	<b>59</b>
<b>Commonwealth of Massachusetts</b> .....	<b>61</b>
<b>Appendix A - Lighting Instructions Plate</b> .....	<b>63</b>
<b>Appendix B - Remote Control Operation</b> .....	<b>64</b>
<b>Appendix C - Wall Switch Operation</b> .....	<b>71</b>
<b>Appendix D - HeatShift System</b> .....	<b>72</b>
<b>Appendix E - Spare Parts</b> .....	<b>88</b>

# Fireplace Safety

This manual contains very important information about the safe installation and operation of the fireplace. Read and understand all instructions carefully before installing and operating the fireplace. Failure to follow these instructions may result in possible fire hazard and will void the warranty.

Replacement manuals are available by contacting the Valor Customer Service at 1-800-468-2567, or by visiting [valorfireplaces.com](http://valorfireplaces.com).

## **WARNING: Extremely Hot!**

### Heat and flammability

- Some parts of the fireplace are extremely hot, particularly the glass windows. Use the barrier screens provided or a gate to reduce the risk of severe burns.
- The glass windows can exceed 500°F at full capacity.
- Always keep the appliance clear and free from combustible materials, gasoline, and other flammable vapors and liquids.
- Be aware of hot wall surfaces! The walls directly above the fireplace can get very hot when the fireplace heats. Although safe, it may reach temperatures in excess of 200°F (93°C) depending on choice of optional accessories. Do not touch!
- Be aware of hot hearth/floor surfaces! Any projections directly around the fireplace can get very hot when the fireplace heats. Although safe, they may reach temperatures in excess of 200°F (93°C) depending on elevation of hearth. Be careful of touching these! Temperature of projection surfaces will be reduced when barrier screens are installed.
- Some materials or items, although safe, may discolor, shrink, warp, crack, peel, and so on because of the heat produced by the fireplace. Avoid placing candles, paintings, photos and other combustible objects sensitive to heat or furniture within 36 inches (0.9 m) around the fireplace.
- Due to its high temperatures, the appliance should be located out of traffic areas and away from furniture and draperies.
- Any safety screen, guard, or barrier removed for servicing an appliance must be replaced prior to operating the appliance.

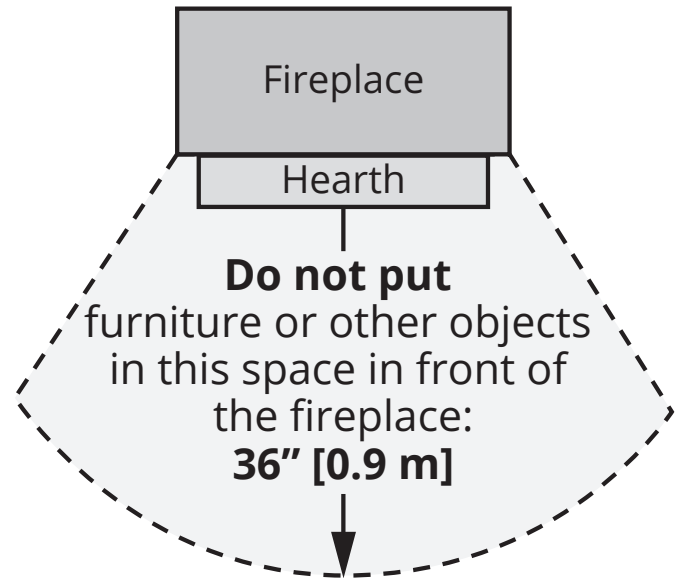

- Children and adults should be alerted to the hazards of high surface temperature and should stay away to avoid burns or clothing ignition.
- Young children should be carefully supervised when they are in the same room as the appliance. Toddlers, young children, and others may be susceptible to accidental contact burns. A physical barrier is recommended if there are at-risk individuals in the house. To restrict access to a fireplace or stove, install an adjustable safety gate to keep toddlers, young children, and other at-risk individuals out of the room and away from hot surfaces.
- A barrier designed to reduce the risk of burns from the hot viewing glass is provided with this appliance and shall be installed for the protection of children and other at-risk individuals.
- Clothing or flammable material should not be placed on or near the appliance.

# Fireplace Safety

## Glass windows

### **WARNING**

**Do not operate this appliance with the glass front removed, cracked, or broken. Replacement of the glass front should be performed by a licensed or qualified service person. Do not strike or slam the glass front.**

- The glass front assemblies must be in place and sealed before the unit can be placed into safe operation.
- The glass front assemblies must only be replaced as complete units, as supplied by the fireplace manufacturer. No substitute material may be used.
- Do not use abrasive cleaners on the glass front assemblies. Do not attempt to clean the glass when it is hot.

## Venting

- This unit must be used with a vent system as described in this manual. No other vent system or components may be used.
- Never obstruct the flow of combustion and ventilation air. Keep the front of the appliance clear of all obstacles and materials for servicing and proper operation.
- This gas fireplace and vent assembly must be vented directly to the outside and must never be attached to a chimney serving a separate solid fuel burning appliance. Each gas appliance must use a separate vent system. Common vent systems are prohibited.

## Intended use

- This appliance is designed and approved as a supplemental heater and provides the potential for most energy conservation when used while attended. The use of an alternate primary heat source is advisable.
- This unit is not for use with solid fuel.
- Do not use this heater as a temporary source of heat during construction.

## Installation and Servicing

- Installation and repair should be done by a qualified service person. The appliance should be inspected before use and at least annually by a professional service person. More frequent cleaning might be required due to excessive lint from carpeting, bedding material, et cetera. It is imperative that control compartments, burners, and circulating air passageways of the appliance be kept clean.

### **WARNING**

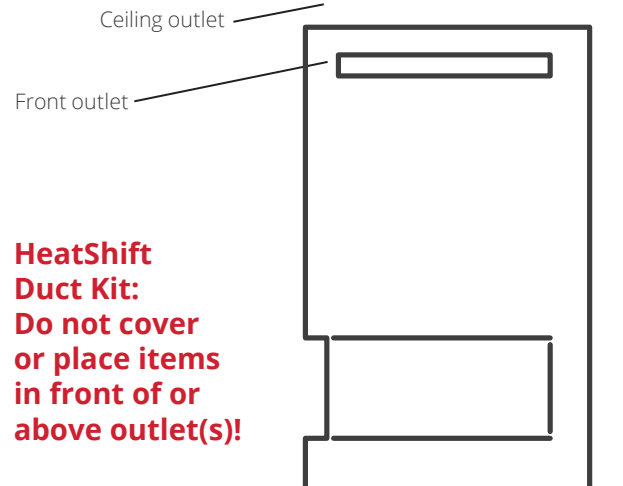

# Specifications

## Approval & Codes

This appliance is certified to ANSI Z21.88/CSA 2.33 American National Standard / CSA Standard for Vented Gas Fireplace Heaters for use in Canada and USA, and to CGA 2.17-91 High Altitude Standard in Canada. This appliance is for direct vent installations.

This appliance complies with CSA P.4.1-15 Testing method for measuring annual fireplace efficiencies.

The installation must conform to local codes or, in the absence of local codes, with the National Fuel Gas Code, ANSI Z223.1/NFPA 54 or the Natural Gas and Propane Installation Code CAN/CGA-B149.1. Only qualified licensed or trained personnel should install this appliance.

This appliance must be electrically grounded in accordance with local codes, or, in the absence of local codes, with the National Electrical Code, ANSI/NFPA 70 or the Canadian Electrical Code, CSA C22.1.

## Ratings

Model	KN	KP
Gas	Natural	Propane
Altitude (Ft.)*	0-4,500 feet*	
Input Maximum (Btu/h)	36,000	36,000
Input Minimum (Btu/h)	19,000	21,000
Manifold Pressure (in w.c.)	3.7"	9.0"
Minimum Supply Pressure (in w.c.)	5"	11"
Maximum Supply Pressure (in w.c.)	10"	14"
Main Burner Injector Marking	DMS#32	DMS#49
Pilot Injector Marking	51	30
Min. Rate By-Pass Screw	220	160

## \*High Altitude Installations

Input ratings are shown in BTU per hour and are certified without deration for elevations up to 4,500 feet (1,370 m) above sea level.

For elevations above 4,500 feet (1,370 m) in USA, installations must be in accordance with the current ANSI Z223.1 and/or local codes having jurisdiction. Heating value of gas in some areas is reduced to compensate for elevation—consult your local gas utility to confirm.

For installations at elevations above 4,500 feet (1,370 m) in Canada, please consult provincial and/or local authorities having jurisdiction.

## Supply Gas

Heater engines

2200LKN / 2200RKN are used with natural gas.

Heater engines 2200LKP / 2200RKP are used with propane gas.

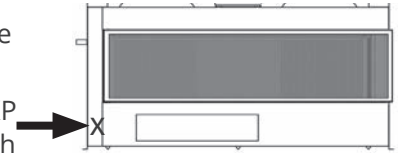

The supply pressure must be between the limits shown in the Ratings section.

The supply connection is 1/2" NPT male and located on the on the rear left side of the firebox.

A shut-off valve (supplied) is required on the supply line to isolate the unit during service. See *Set-up Gas Supply* section for details.

## Conversion Kits

The 2200K LX2 is supplied as natural gas or propane gas and is field convertible between fuels. See instructions packaged with the conversion kits for further information.

## Electrical

The 2200K is designed to run on battery power and does not require an electrical power source to operate as a heater. However, it requires electrical power to operate the interior lighting or the optional 1270RBK Remote Blower Kit.

## HeatShift® System

The 2200 fireplace **MUST** be installed with a HeatShift kit, a convection system that redistributes the warm air flow away from the fireplace opening to a more desirable location using natural convection, without use of a fan.

The warm air flow may be relocated to a position higher up the wall, out the sidewalls, or even to another room. The result is much cooler wall temperatures above the fireplace opening for locating television, artwork, etc.

Refer to "Appendix D - HeatShift System" on page 72 of this manual.



## WARNING

**Please note that the HeatShift Kit MUST be installed on this appliance!**

# Kits & Accessories

**Required Kits** Information accurate at the time of printing and subject to change without notice.

4006797	LX2 Barrier Screen—Front panel
4006888	LX2 Barrier Screen—Side panel
<b>Fuel Beds (choose one)</b>	
1700BLK	Birch Log Kit
1705DWK	Driftwood Set Kit
2200DGM	Murano Glass Set
2200DGS	Decorative Glass Set
1700SWK	Splitwood Kit
1700RSS	Rocks & Shale Set
<b>Liners + Liner End Panel (choose one)</b>	
2200FBL + 2200FBP	Fluted Black Liners + Fluted End Panel
2200RGL + 2200RGP	Reflective Glass Liners + Reflective Glass End Panel
2200LML + 2200LMP	Limestone Liners + Limestone End Panel
<b>HeatShift®</b>	
LDK1	Quad Plenum 48"
LDK3	Double Plenum 14" (2) with Grille
LDK4	Quad Plenum 38"
LDK7	Duct Termination Plates (valance outlet)
LDK9	Quad Plenum 30"

**Optional Accessories** Information accurate at the time of printing and subject to change without notice.

<b>Gas Conversion Kits</b>	
2200XPGK	Conversion to propane gas
2200XNGK	Conversion to natural gas
<b>Other Accessories</b>	
LDK2	48" Finishing Frame for LDK1
LDK5	38" Finishing Frame for LDK4
LDK6	5" dia. Aluminum 2-ply Flex Kit—2 x 10' lengths, may be cut to required length
LDK10	30" Finishing Frame for LDK9
2200SFK	Steel Framing Kit
1270RBK	Remote Blower Kit (with LDK1 or LDK4 ONLY)
Hearth Gate	Hearth gates such as Cardinal's VersaGate are available at retail stores carrying safety products for children.

# Dimensions & Location

## Dimensions—Corner Right Appliance Shown

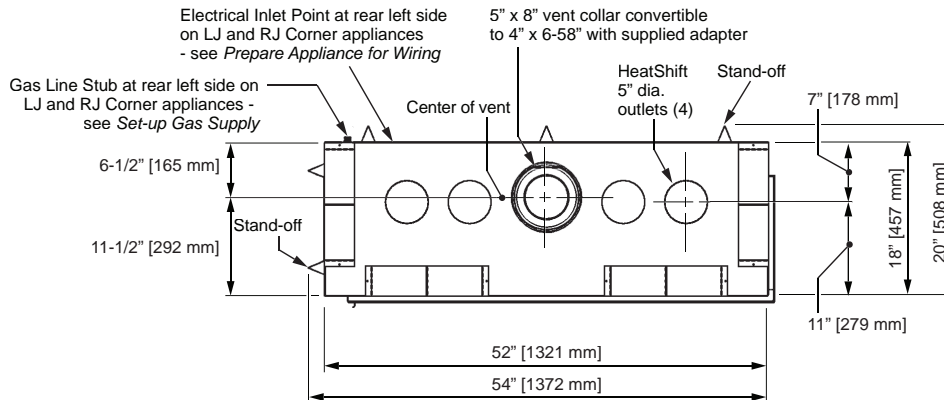

Top View

**Gas Line Stub & Electrical Inlet Point at rear, on left side for both LJ and RJ corner appliances**

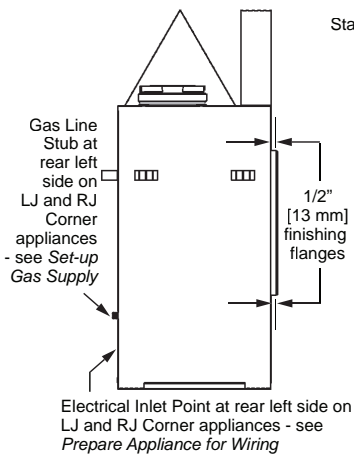

Left Side View

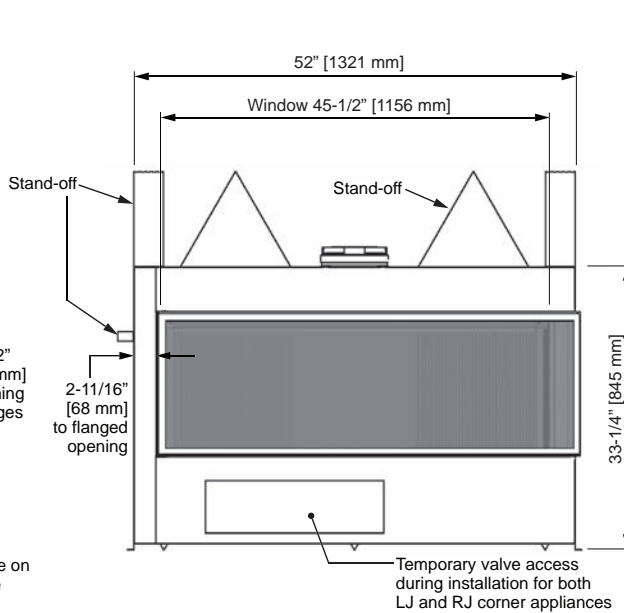

Front View

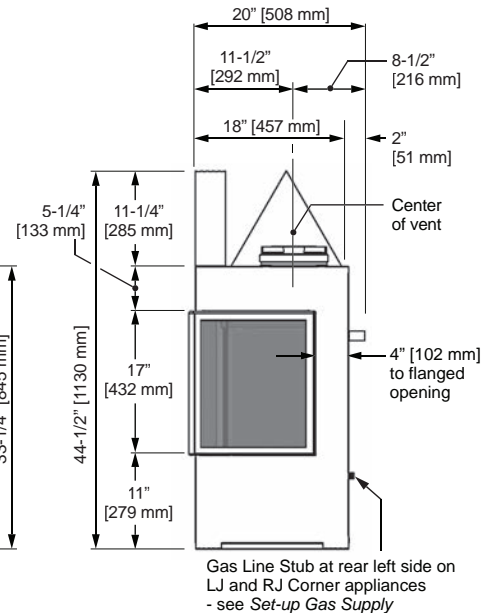

Right Side View

## Location—Corner Right Appliance Shown

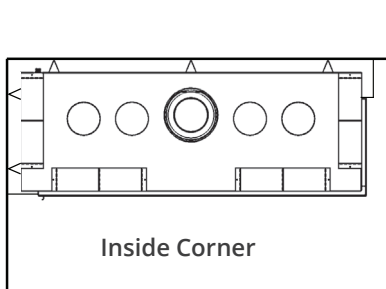

Inside Corner

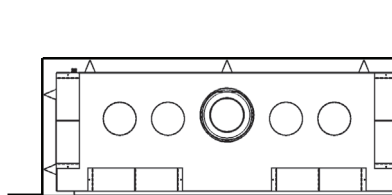

Outside Corner

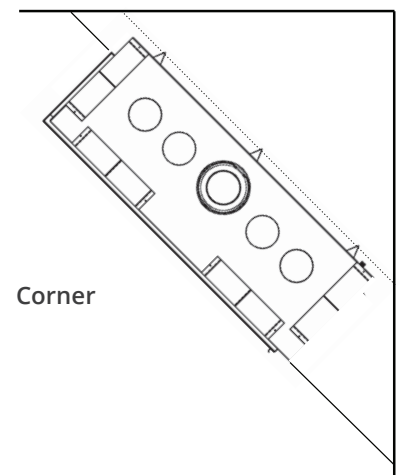

Corner



# Planning

## Installer—READ THIS FIRST

### 1. YOU NEED TO KNOW FROM THE HOMEOWNER:

- Height of appliance;
- HeatShift components;
- Thickness and type of wall finish around appliance;
- Accessories used;
- Venting configuration - 4 x 6-5/8 or 5 x 8

2. Unpack the appliance and recycle the packaging EXCEPT THE CARTON PROTECTING THE BARRIER SCREEN—KEEP IT!

3. Remove front window and all items inside firebox.

4. Check that you have everything, using Pack Content sheet. Also, check that you have:

- fuel bed (packed separately)
- liners (packed separately)
- Remote Battery & Wall Switch Kit RBSWK
- HeatShift Kit (mandatory)
- Gas conversion kit if necessary
- Venting accessories
- Electrical accessories

5. Carefully read the Installer's Checklist included with the fireplace for the installation sequence.

Please note that the following steps must be done BEFORE the appliance is placed in its final position in the cavity since the connections are done from the back of the appliance:

- electrical connections
- gas connections
- gas conversion (if needed)
- wiring of the Remote Battery & Wall Switch Kit RBWSK



### Caution

Only qualified licensed or trained personnel should install this appliance.



### WARNING

Please note that the HeatShift Kit **MUST** be installed on this appliance!

## **⚠ WARNING**

**Ensure weight of wall above is NOT carried by the appliance.**

Vent collar supplied as 5 x 8" outlet, field convertible to 4 x 6-5/8" outlet (adapter supplied). Note - Vertical rise required in vent system when adapting to 4 x 6-5/8" venting

HeatShift Plenum (front or sides) or Duct Termination Plates (top) **mandatory!** HeatShift system supplied separately—see "Appendix D - HeatShift System" on page 72

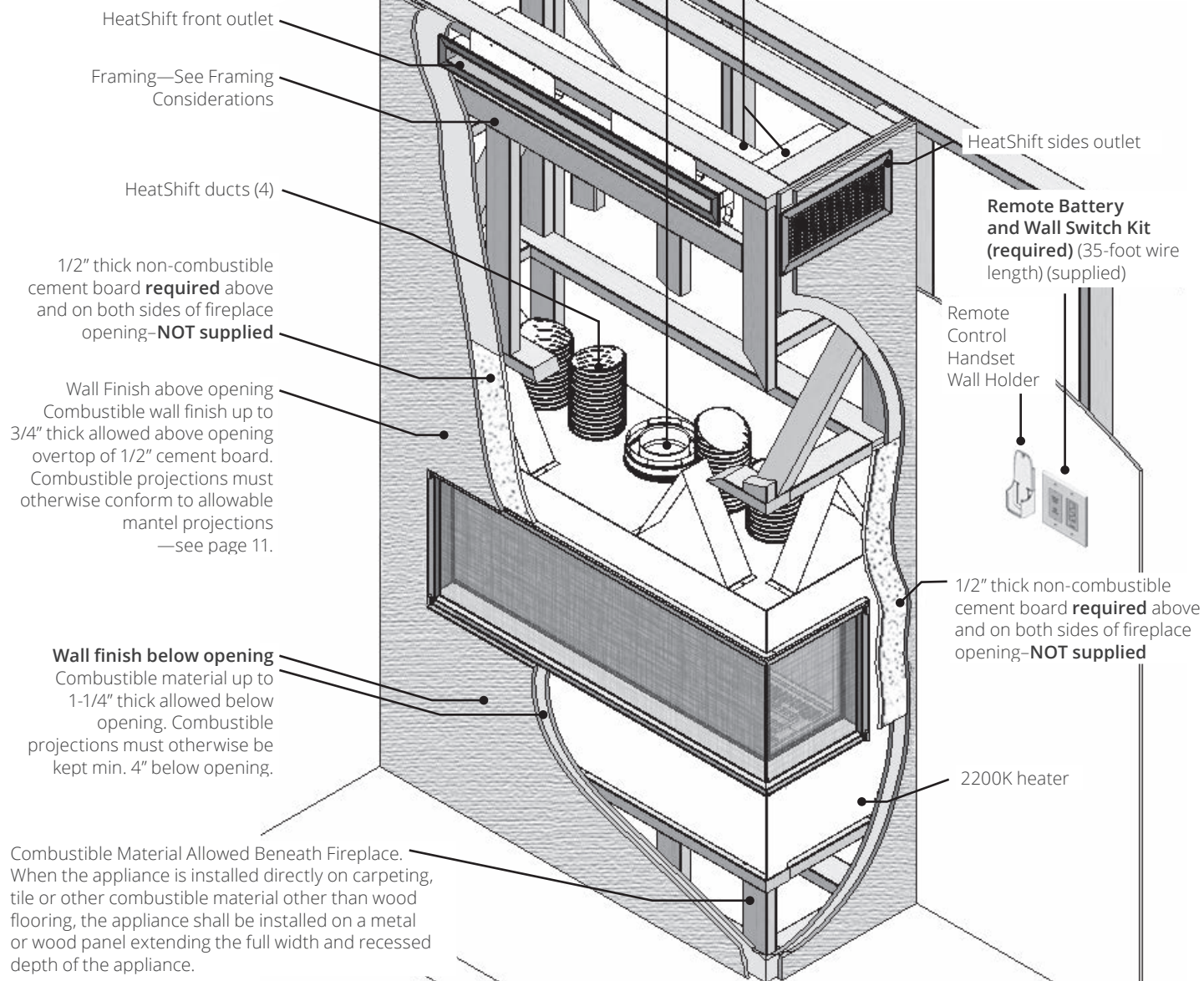

## **⚠ WARNING**

**Some materials or items, although safe, may discolor, shrink, warp, crack, peel and so on because of the heat produced by the fireplace. Avoid placing candles, paintings, photos, and other items sensitive to heat around the fireplace.**

## **⚠ WARNING**

**HOT WALL SURFACES! The walls directly above the fireplace are constructed of non-combustible materials and, although safe, it may reach temperatures in excess of 175°F depending on choice of materials. Do not touch! Finish the walls using materials suitable for these temperatures.**

# Planning

## Clearances—Combustible Projections

### **WARNING**

Ensure weight of wall above is **NOT** carried by the appliance.

 Non-combustible material

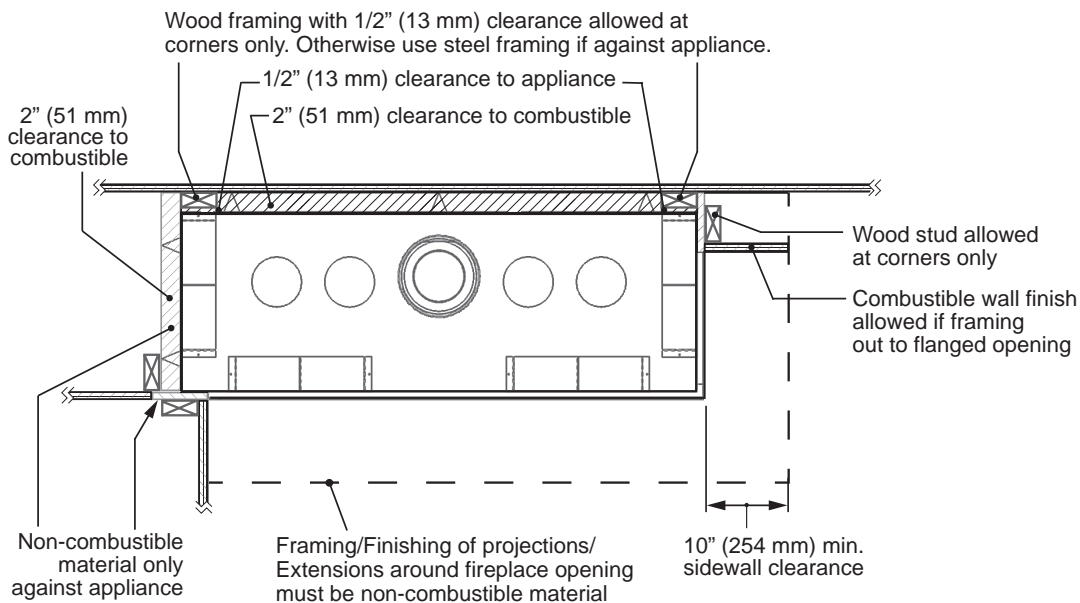

Combustible projections allowed in this area provided area is separated from the main cavity by non-combustible wall finish. Otherwise everything below stand-off height and within cavity must be non-combustible.

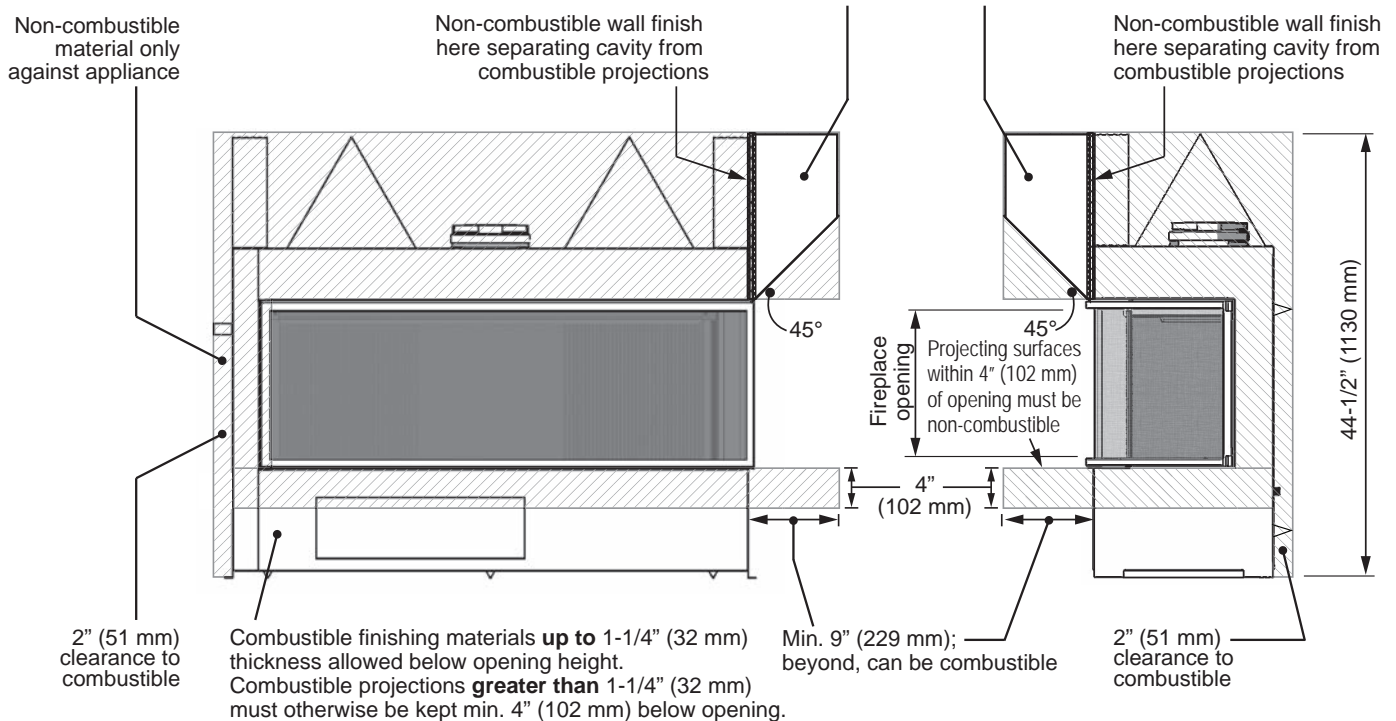

# Planning

## Clearances—Alcove

Alcove above opening

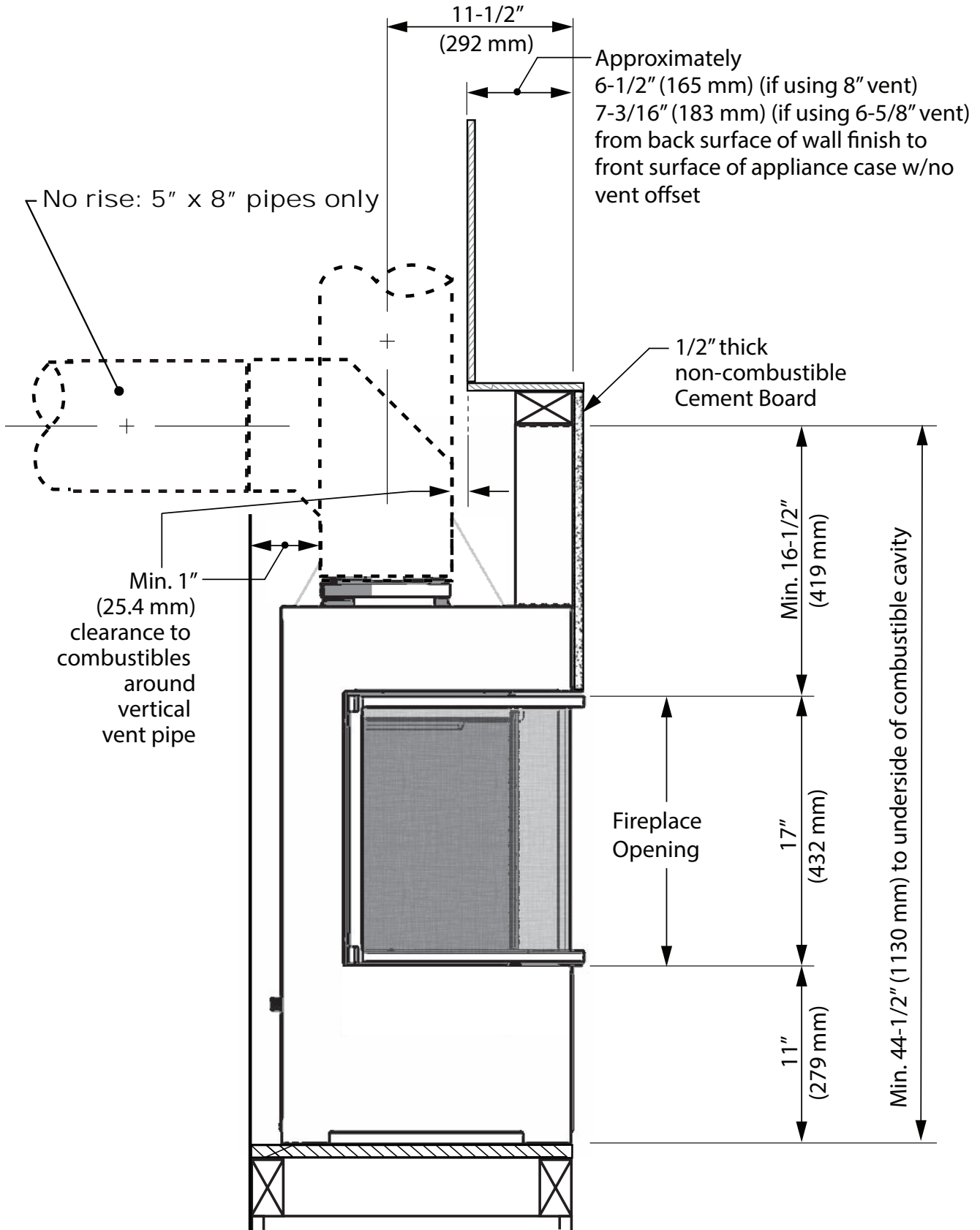

# Planning

## Minimum Vertical Vent—6-5/8" Vent

\* This is the minimum vent height when using 6-5/8 inch venting. If calculating the vent height using additional vent lengths, subtract approximately 1-1/2 inch for each pipe joint. For example, an additional 12-inch pipe section will add approximately 10-1/2 inches overall to this dimension. Alternatively, substituting a 24-inch pipe length for the min. 12-inch section will add 12 inches to this dimension as there is no additional pipe joint.

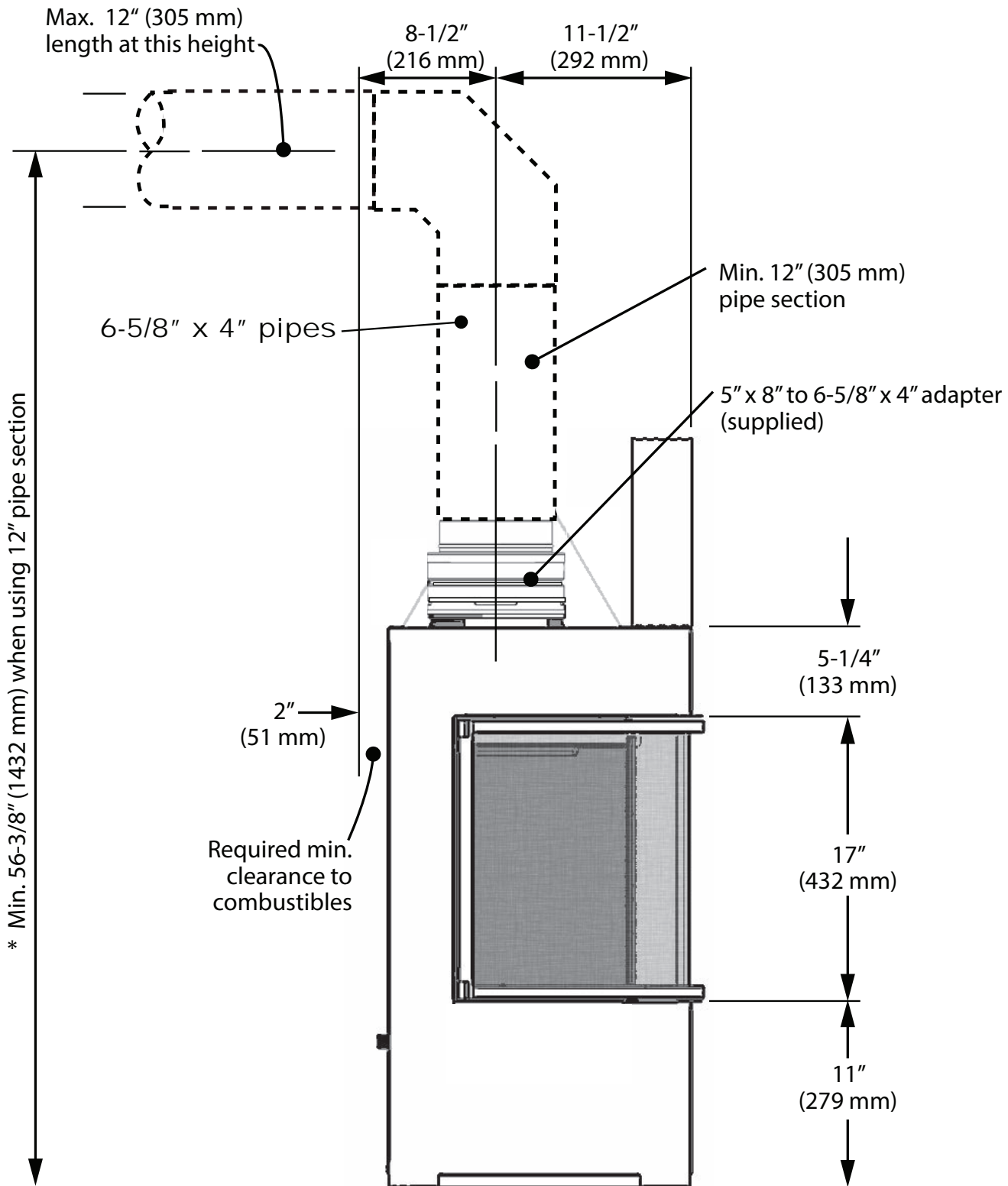

# Planning

## Minimum Vertical Vent—8" Vent

\* This is the minimum vent height when using 8-inch venting. If calculating the vent height using additional vent lengths, subtract approximately 1-1/2 inch for each pipe joint. For example, an additional 12-inch pipe section will add approximately 10-1/2 inches overall to this dimension.

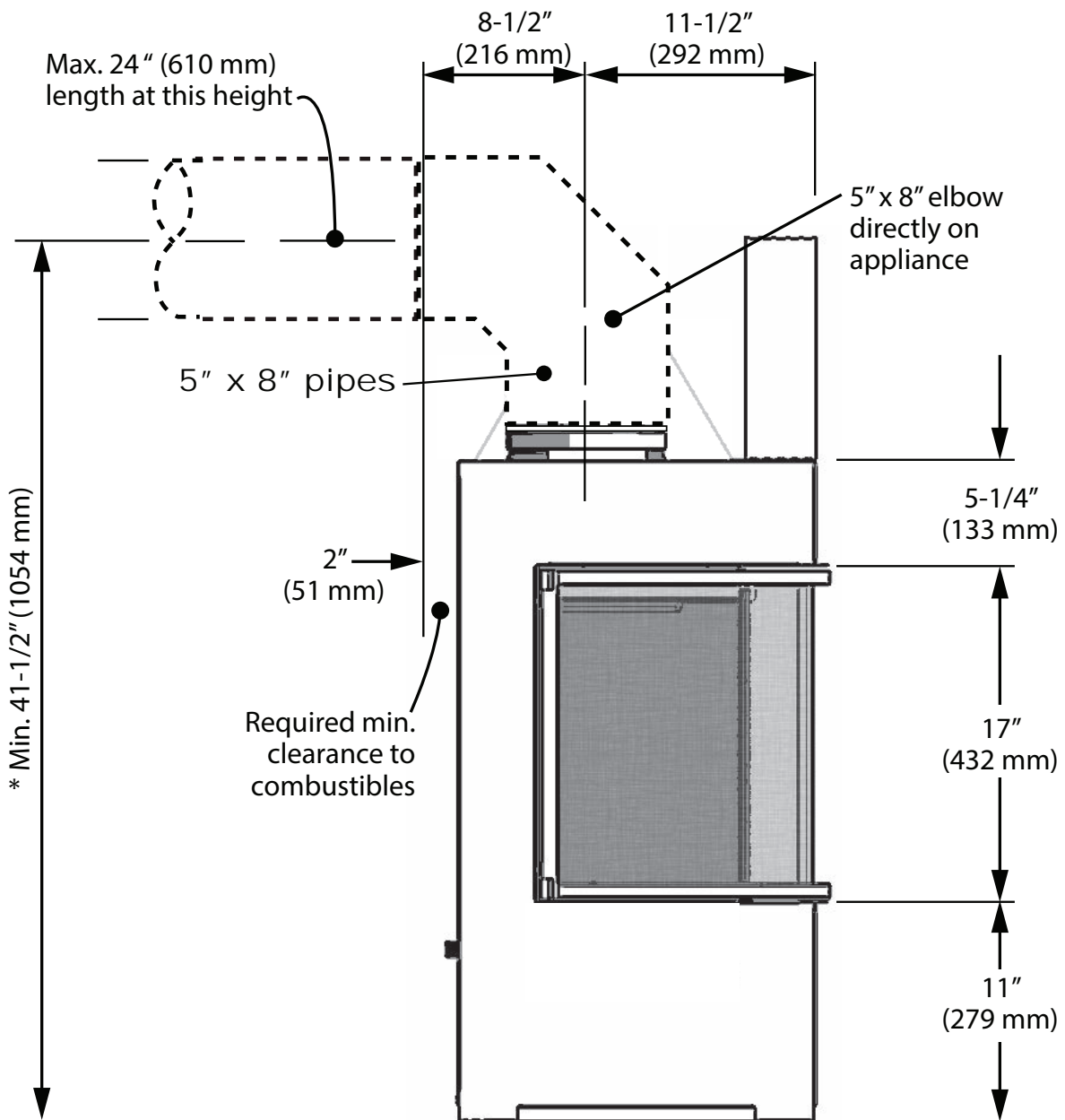

# Planning

## Framing—Minimal

### **WARNING**

Ensure weight of wall above is NOT carried by the appliance.

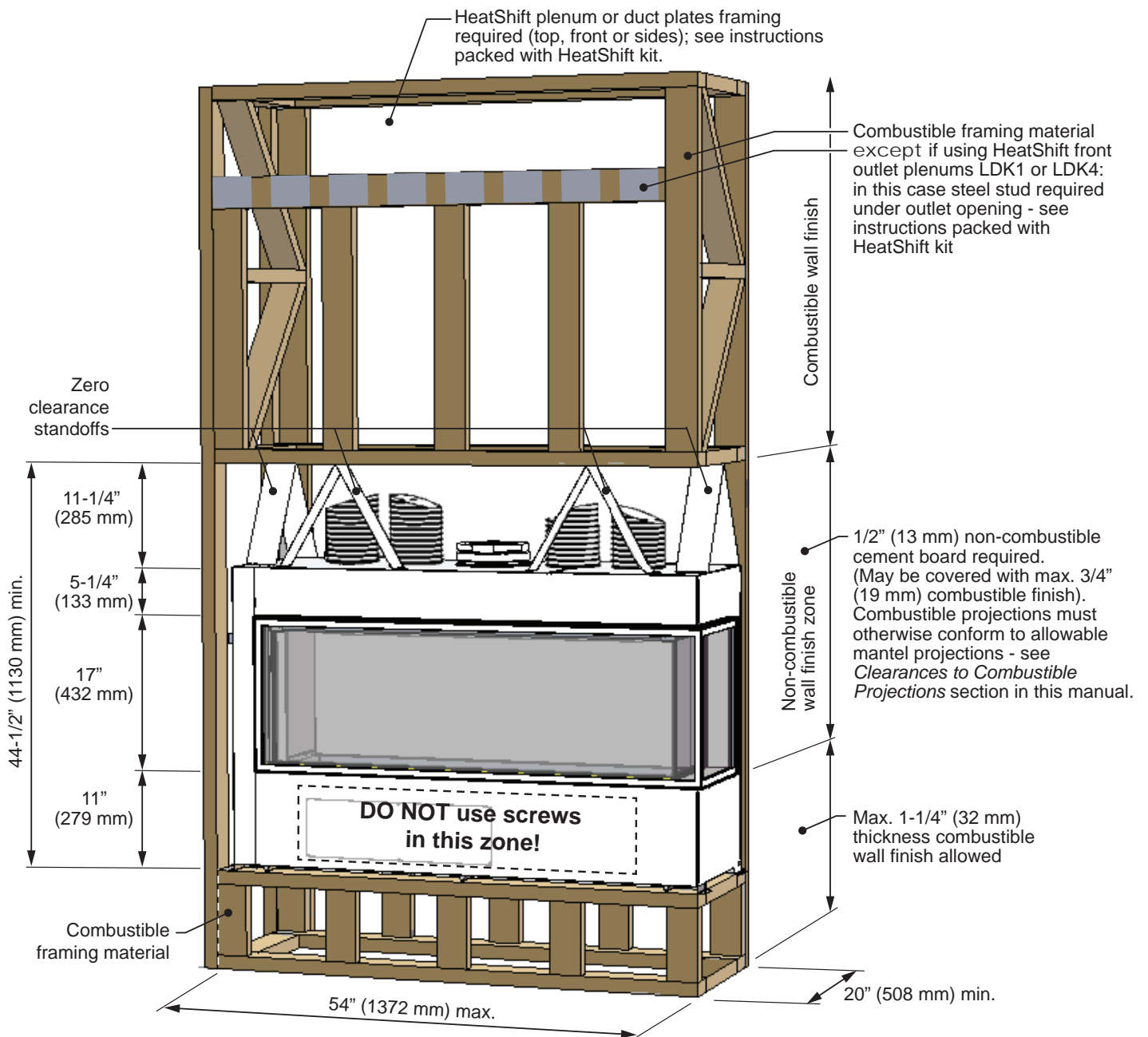

# Planning

# Framing—Extended

## **WARNING**

Ensure weight of wall above is **NOT** carried by the appliance.

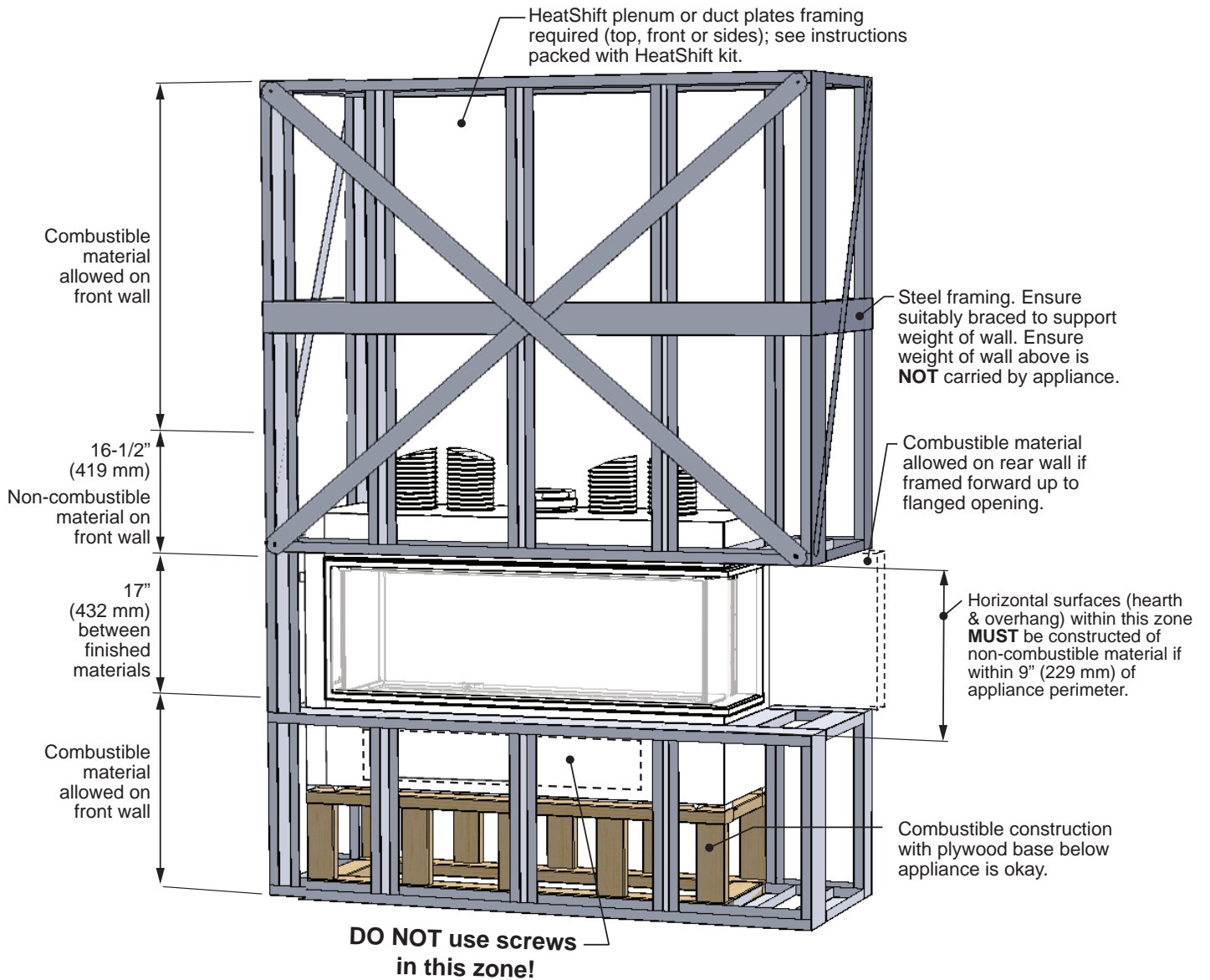



### Plan Wall Finish

#### Non-Combustible Materials Specifications

Material which will not ignite and burn. Such materials are those consisting entirely of steel, iron, brick, tile, concrete, slate, glass or plasters, or any combination thereof.

Materials that are reported as passing ASTM E 136, Standard Test Method for Behavior of Materials in a Vertical Tube Furnace at 750 °C shall be considered non-combustible materials.

#### Combustible Materials Specifications

Materials made of or surfaced with wood, compressed paper, plant fibers, plastics, or other material that can ignite and burn, whether flame proofed or not, or plastered or unplastered shall be considered combustible materials.

#### Non-combustible cement board

The LX2 fireplace requires a 1/2" (13 mm) thick non-combustible cement board to be used as a wall surface immediately above the unit opening in the front and above and behind the opening on each side.

Extending the cement board well beyond the minimum will help avoid cracking due to differential expansion of materials.

Pre-drill cement board with oversized holes and do not over-tighten screws to avoid cracking due to heat expansion.

Standard gypsum wall board may be used beyond the perimeter of the cement board.

#### Non-combustible finishing over cement board

Additional non-combustible material such as tile, etc., may be applied over top of the cement board or you may choose to leave it finished clean with no tile.

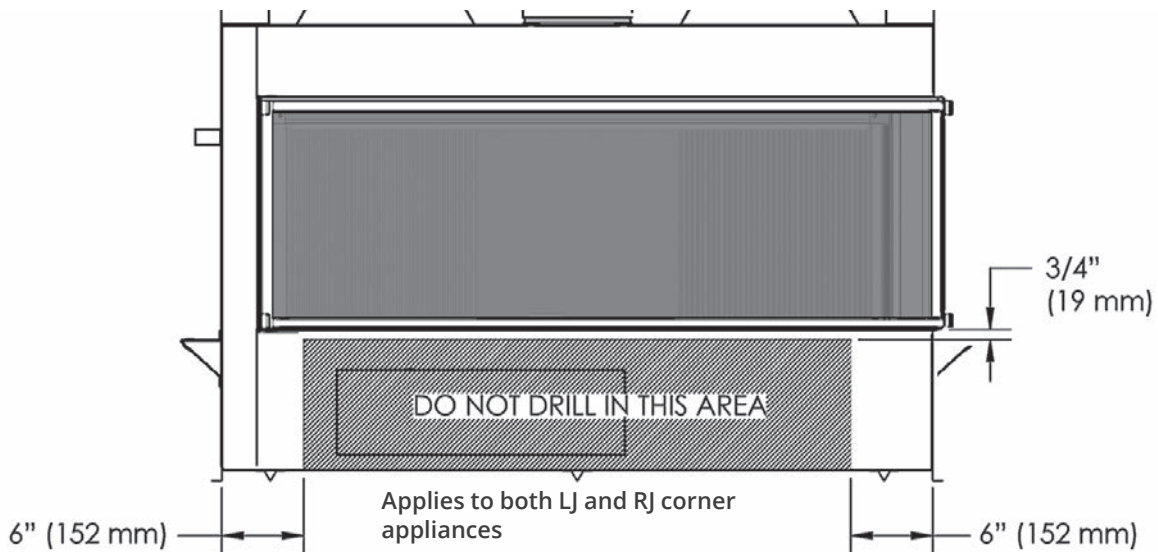

# Planning

## Wall Finish

### Cracking wall finishes

The HeatShift system reduces the wall temperatures and minimizes the possibility of cracking wall finishes.

If a clean finish with no tile, etc. is desired, joints in the cement board and the transition to gypsum board will require special attention if future cracking is to be controlled. Be aware that temperatures on the non-combustible wall surface above the appliance can exceed 175°F.

Below are some tips on how to best avoid any cracking:

- Allow materials to dry thoroughly before finishing the wall. Cement board has the ability to absorb up to 30 percent of its weight in water and may shrink as much as 1/8" over a 48" length when drying from a saturated condition. Running the fireplace before final finishing will help drive out moisture.
- Always pre-drill screw holes through cement board and use screws with self-milling head.
- Always use tape over joints.
- Behind joints, double up studs or use studs "on the flat" to add extra support to the joint. Adhesive on the backside of wall board behind any joints can help control differential movement.
- Use multiple, thinner coats of joint compound and allow to dry thoroughly between coats.
- Ensure framing materials are dry.
- After finishing the wall, introduce heat gradually to slowly dry any excess moisture rather than drying too fast.
- Avoid notching cement board or tiles around corners of window opening and instead provide a joint that intersects the corner.

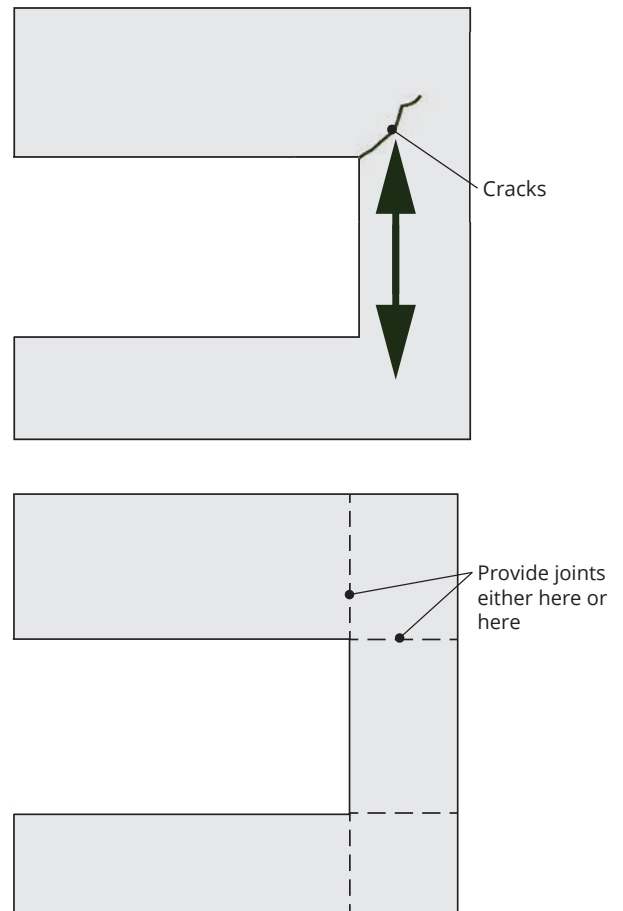

### Vent Material

This unit is approved for installation using 5 x 8 inches co-axial direct vent pipe and accessories as listed in the “Approved Venting Components” on page 59 of this manual. Follow the installation instructions supplied with the individual venting accessories.

This unit may also be converted to 4 x 6-5/8 inches co-axial direct vent pipe and accessories using the adapter supplied with the appliance—see list in the “Approved Venting Components” on page 59 of this manual.

### Vent Sealing

Seal all outer coaxial pipe and elbow joints, including sectioned elbow joints, using high quality, high temperature 2 inch wide self-adhesive aluminum foil tape (Nashua-322-2 brand or similar). Wrap the tape completely around all joints and press firmly to seal.

A high temperature black silicone sealant may be used in the outer joints as a substitute to foil tape.

Ensure all the pipe joints have a minimum of 1 ¼ inch overlap.

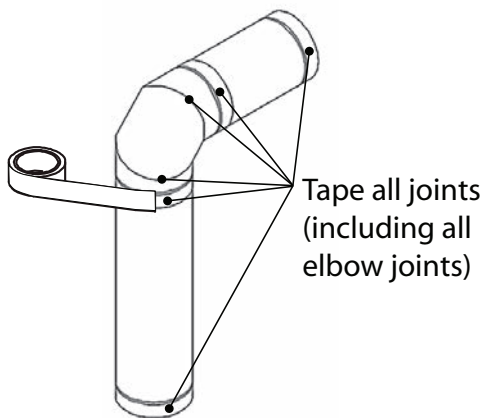

### Wall Thickness

The appliance vent is suitable for penetrating a combustible wall assembly up to 8 inches in thickness. A non-combustible wall can be of any thickness up to the maximum horizontal run of vent pipe allowed for the particular installation.

### Framing Vent in Combustible Walls & Ceilings (6-5/8" and 8" pipes)

When penetrating through combustible walls and ceilings, frame a **minimum of 10 in x 10 in** opening and ensure that the insulation is kept clear of the vent pipe using either a wall thimble or an attic insulation shield. Note that some vent manufacturers' wall thimble dimensions may require larger framed openings—follow the installation instructions supplied with the individual venting components.

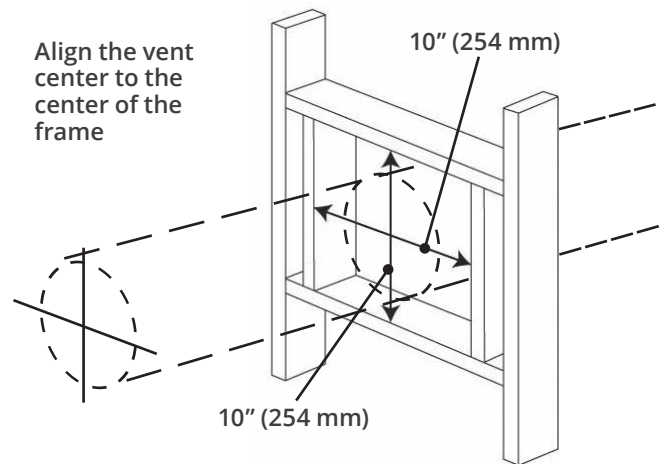

### Important Installer Notice – Weather Sealing & Vapor Barriers

It is the installer's responsibility to ensure that vent installations through exterior walls are caulked and weatherproofed in such a manner as to:

- Prevent rain water from entering the wall from the weather side by adequately caulking the outer vent plate to the exterior wall surface.
- Prevent moisture inside the home from penetrating into the wall structure by ensuring the inside wall plate is adequately sealed to the inside vapor barrier.
- Prevent rain water and moisture from entering the walls by sealing the joints between the outer vent tube and the inner and outer wall plates.

We recommend the use of a high quality polyurethane sealant.

All horizontal pipe runs must be graded 1/4 inch per foot upwards in the direction of the exhaust flow. The final pipe length, when terminating through the wall may be graded downwards slightly to prevent water migration.

# Venting

## Typical Components

### Typical Co-axial Venting Components

Appliance provided with 5 x 8" vent collar and 4 x 6-5/8" vent adapter.

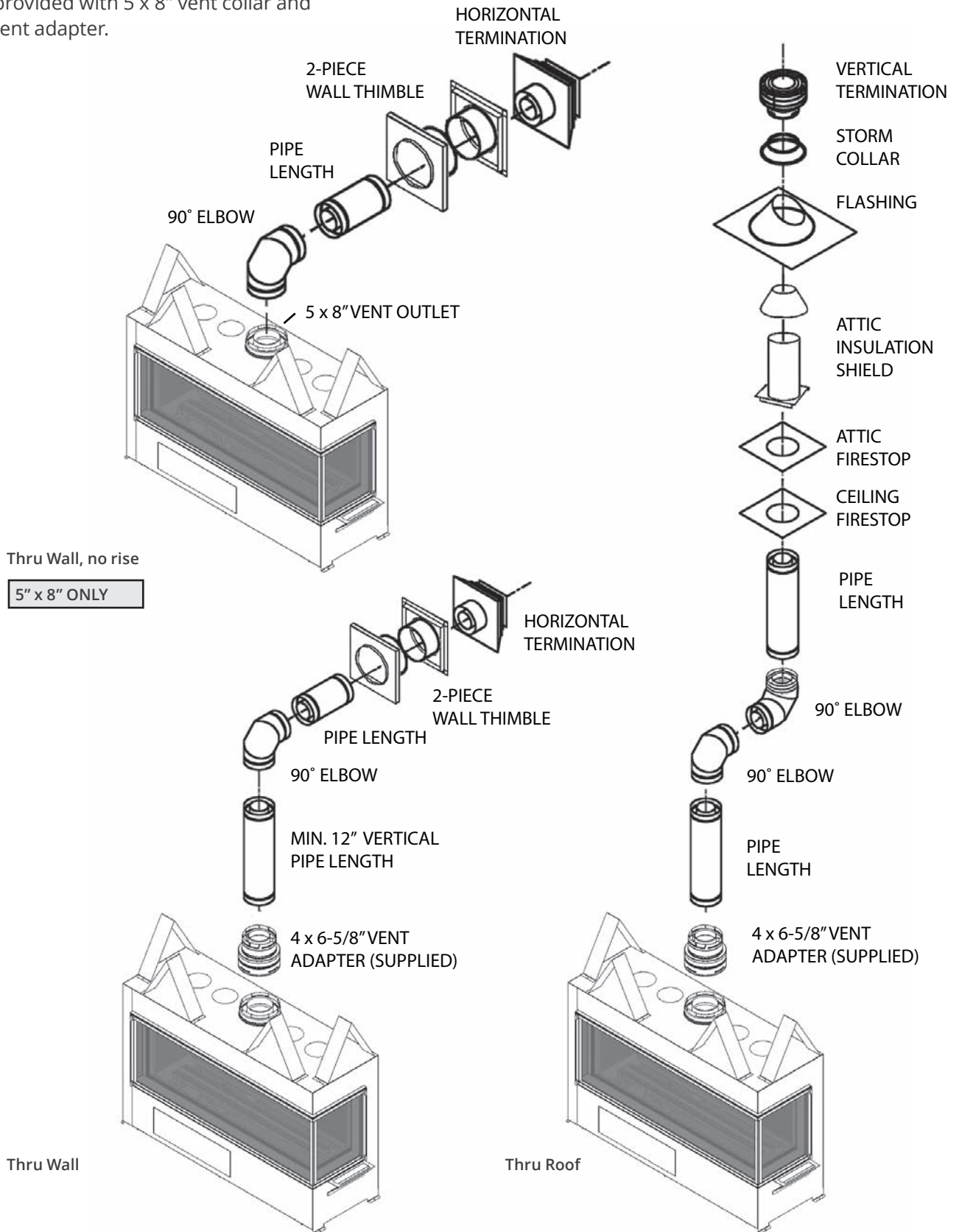

# Venting

## How to Read the Venting Chart

The chart below applies to co-axial roof or wall termination.

1. Minimum 12 inch vertical pipe section required right at unit when using 6-5/8" venting.
2. The total length of the vent pipe cannot exceed 40 feet.
3. The minimum vertical height with roof termination is 6 feet.
4. Any combination of rise and run can be used as long as they are within the allowable limits shown on the chart below.
5. A maximum of 4 x 90 degrees elbows—or equivalent (2 x 45 degrees = 90 degrees)—can be used.

## Venting Chart with 4" x 6-5/8" pipes

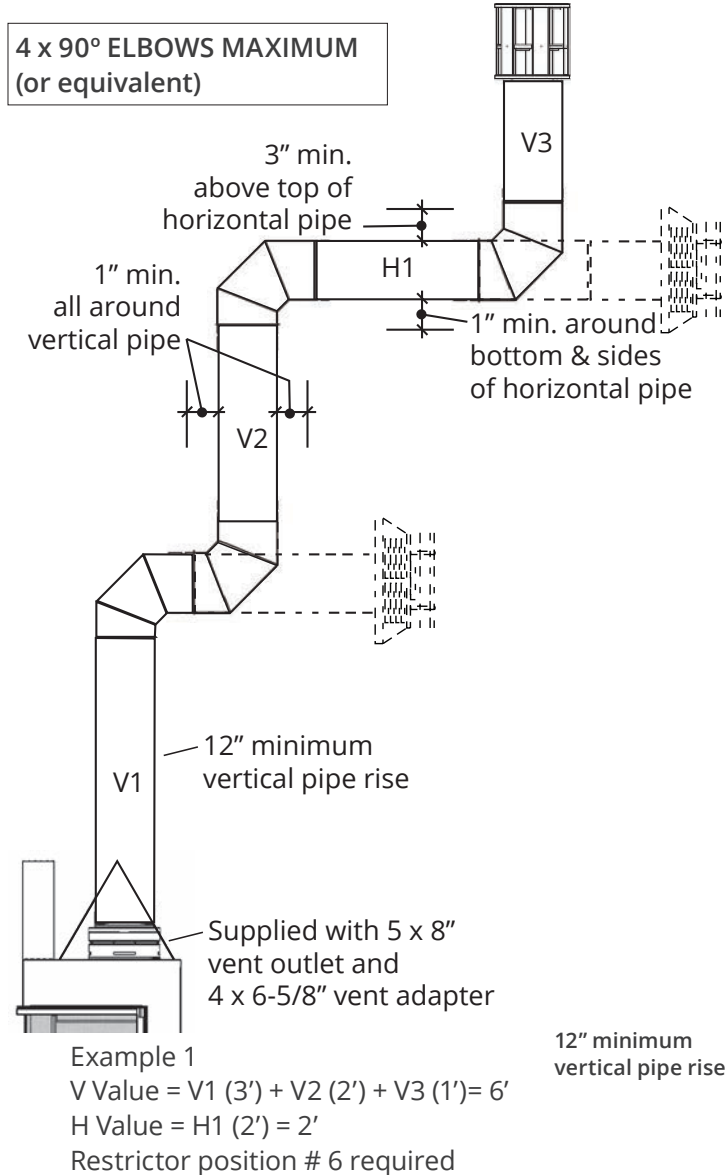

## Venting Chart—4" x 6-5/8"

6. Each 90 degrees elbow installed on the horizontal plane is equivalent to a 3 feet horizontal pipe; therefore, 3 feet must be subtracted from allowable horizontal run. (45 degrees elbow is equivalent to 18 inches horizontal pipe.)
7. All horizontal pipe runs must be graded 1/4 inch per foot upwards in the direction of the exhaust flow. The final pipe length, when terminating through the wall may be graded downwards slightly to prevent water migration.
8. A restrictor adjustment is required for most installations having a vertical rise—see next section.  
**Note:** The restrictors are shipped installed at the exhaust exit of the firebox.

## Allowable Co-Axial Vent Configurations with restrictor positions — with 4" x 6-5/8" pipes

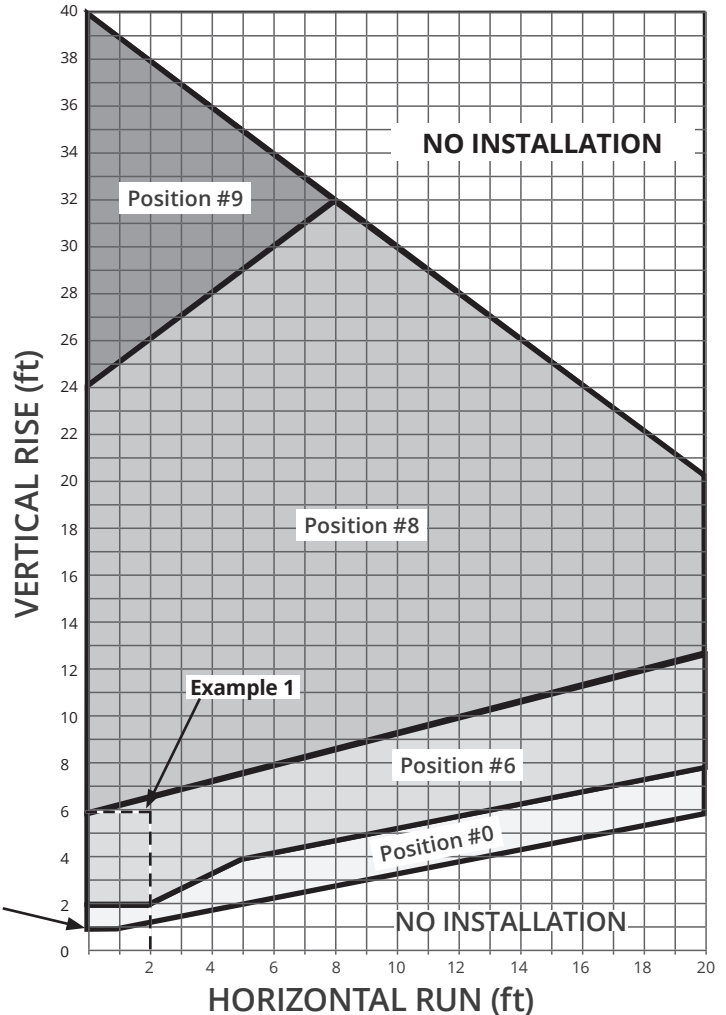

# Venting

## Venting Chart—5" x 8"

### How to Read the Venting Chart

The chart below applies to co-axial roof or wall termination.

1. Maximum 24 inch horizontal pipe section allowed when using a 90 degrees elbow directly at the appliance.
2. The total length of the vent pipe cannot exceed 40 feet.
3. The minimum vertical height with roof termination is 6 feet.
4. Any combination of rise and run can be used as long as they are within the allowable limits shown on the chart below.
5. A maximum of 4 x 90 degrees elbows—or equivalent (2 x 45 degrees = 90 degrees)—can be used.

6. Each 90 degrees elbow installed on the horizontal plane is equivalent to a 3 feet horizontal pipe; therefore, 3 feet must be subtracted from allowable horizontal run. (45 degrees elbow is equivalent to 18 inches horizontal pipe.)
7. All horizontal pipe runs must be graded 1/4 inch per foot upwards in the direction of the exhaust flow. The final pipe length, when terminating through the wall may be graded downwards slightly to prevent water migration.
8. A restrictor adjustment is required for most installations having a vertical rise—see next section.  
**Note:** The restrictors are shipped installed at the exhaust exit of the firebox.

### Venting Chart with 5" x 8" pipes

4 x 90° ELBOWS MAXIMUM  
(or equivalent)

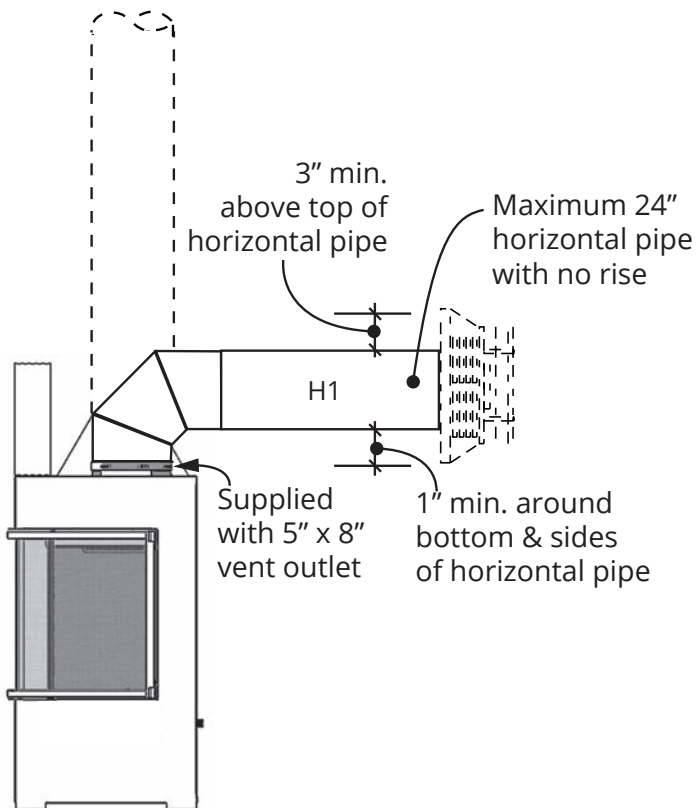

### Allowable Co-Axial Vent Configurations with restrictor positions — with 5" x 8" pipes

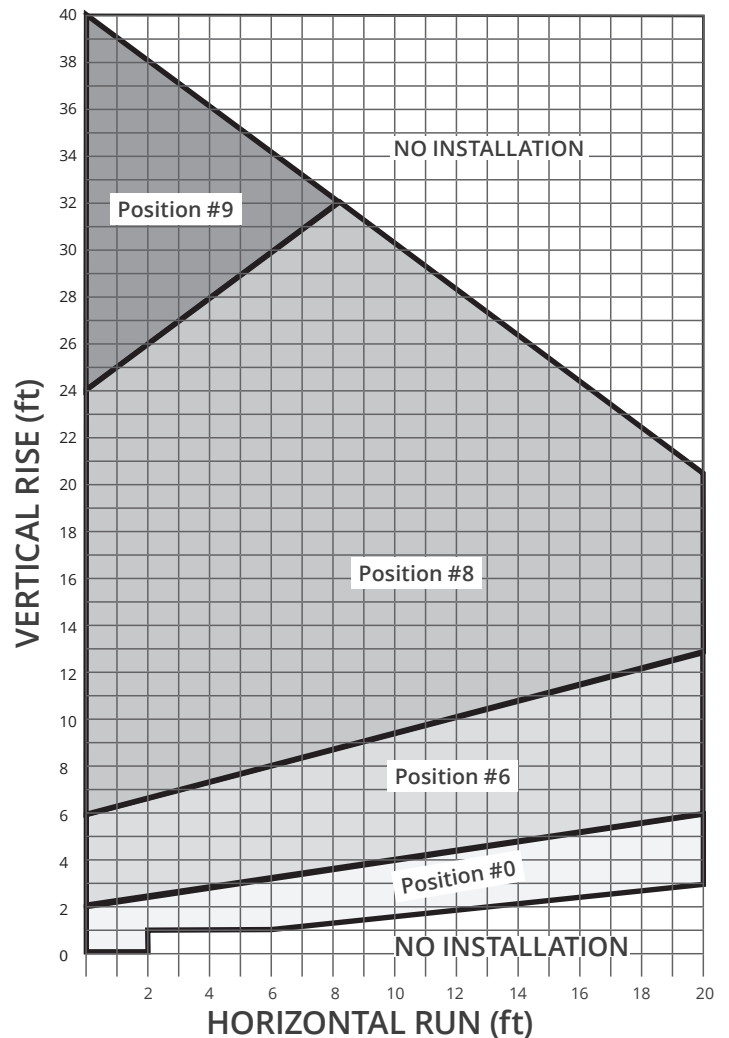

# Venting

## Restrictors

### Restrictors

**ALL INSTALLATIONS REQUIRE A RESTRICTOR** for improved flame picture and performance. This unit is supplied with a pre-fitted restrictor having different positions or settings. The restrictor is shipped mounted at the maximum open position. The level of restriction required depends on the vertical rise in the venting system and, to a lesser degree, the horizontal run and number of elbows.

The amount of restriction is based on laboratory tests. The ideal restrictor position may vary slightly, especially when the vent pipe length is near the limits of the acceptable configurations for each type of restrictor.

The chart on the previous page shows the vent restrictor required relative to the length of the vent pipe.

The restrictors are located in the roof of the firebox hidden above the top panel.

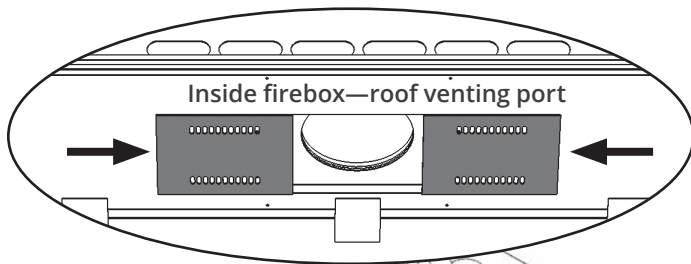

To access the restrictors, remove the top panel:

1. Remove 4 screws along the front or back of the panel.
2. Release 4 screws along the other side of the panel. It is not necessary to remove the screws.

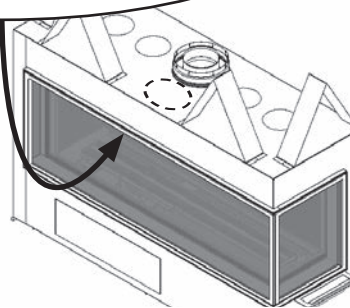

3. Slide the panel to unhook it and set aside.
4. The restrictors are set in position 0, 0 at the factory. The position 0 is at the center and the position 10 is the farthest away from the center. Adjust the restrictors position as needed—up to position 9—**DO NOT CLOSE ALL THE WAY TO POSITION 10!**

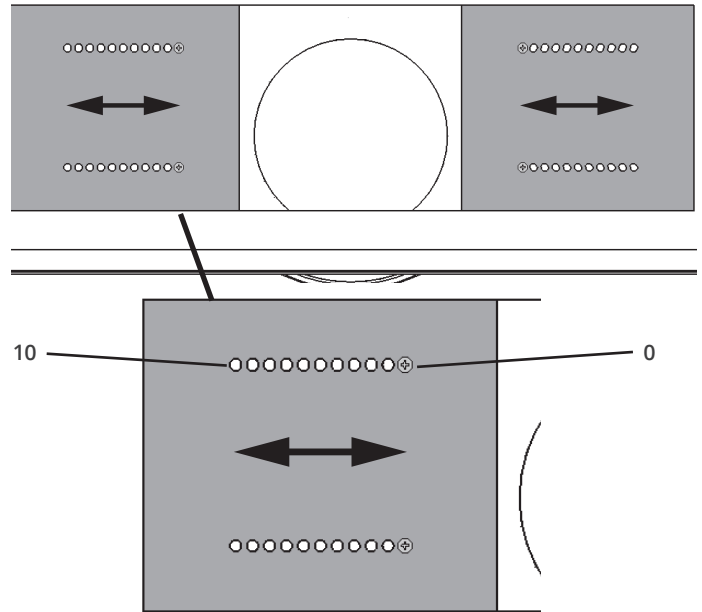

- a. Establish the required position of the restrictors looking up the appropriate venting table (according to vent pipes size) on the previous pages.
  - b. Remove the screws (2) on each restrictor already installed **on the firebox roof port**.
  - c. Slide the restrictors in the required positions.
  - d. Refit and tighten the screws.
5. Reinstall the top panel sliding it on the screws previously released; tighten the screws.
  6. Refit and tighten the screws previously removed.

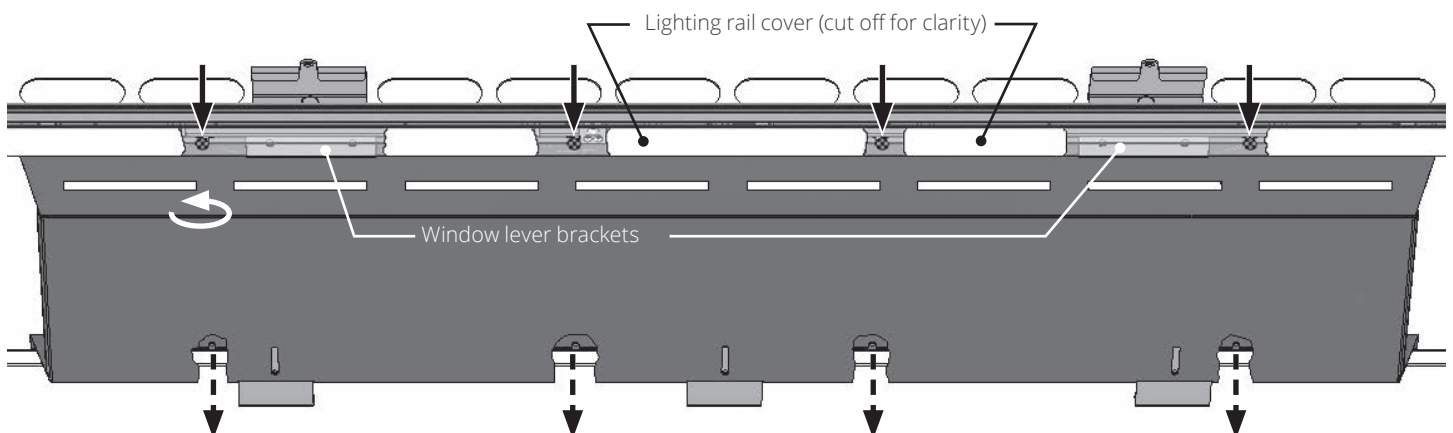

# Venting

## Wall Termination

### Horizontal Vent Termination Location

- The vent terminal must be located on an outside wall or through the roof.
- This direct vent appliance is designed to operate when an undisturbed airflow hits the outside vent terminal from any direction.
- The minimum clearances from this terminal that must be maintained when located on an outside wall are shown in figure below. Any reduction in these clearances could result in a disruption of the

airflow or a safety hazard. Local codes or regulations may require greater clearances.

- The vent terminal must not be recessed into a wall or siding.
- The vent terminal should be positioned where any snowdrifts will not cover it.
- Sidewall vent terminations require a terminal guard such as 658TG or 845TG when accessible—within 7' of ground.

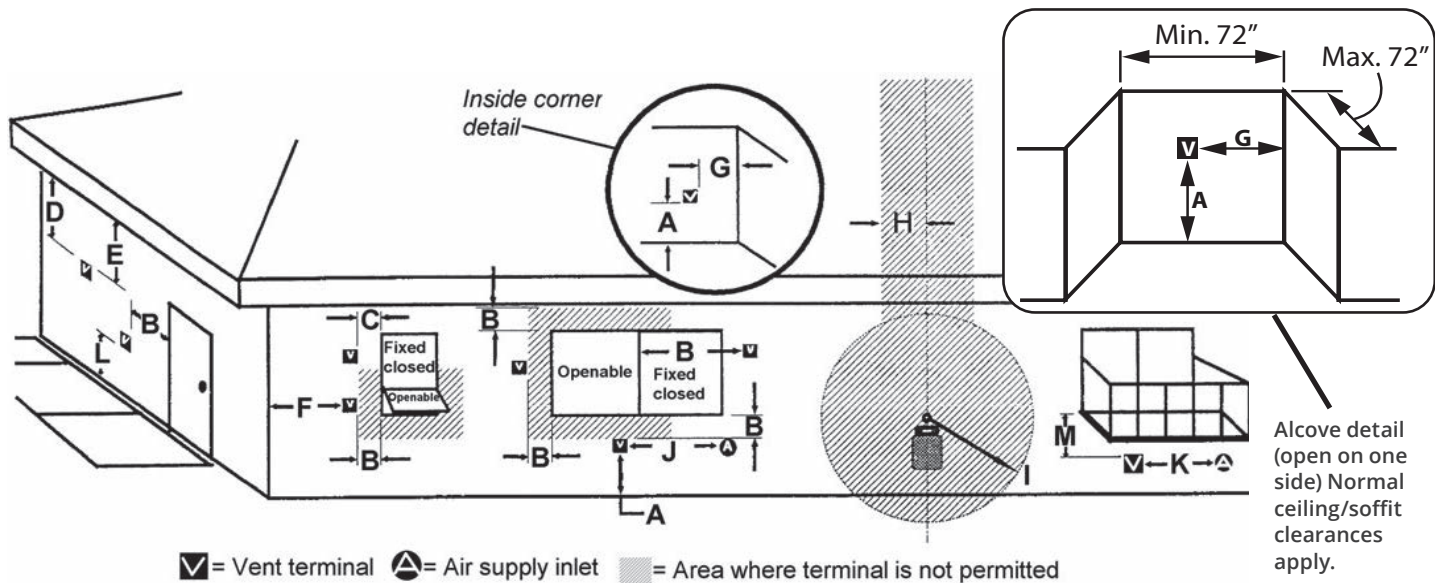

KEY	VENT TERMINAL LOCATIONS - MINIMUM DISTANCES	MINIMUM CLEARANCE	
		Inches	Cm
A	Clearance above grade, verandah, porch, deck or balcony	12	30
B	Clearance to window or door that may be opened	12	30
C	Clearance to permanently closed window (recommended to prevent condensation on window)	12	30
D	Vertical clearance to ventilated soffit located above the terminal within a horizontal distance of 2 feet (60 cm) from the center-line of the terminal	18	46
E	Clearance to unventilated soffit	12	30
F	Clearance to outside corner (measured from the center of vent)	12	30
G	Clearance to inside corner (measured from the center of vent)	12	30
H	Horizontal clearance to center-line of meter/regulator assembly located within 15 feet (4.6 m) below the terminal	36	90
I	Clearance to service regulator vent outlet	36	90
J	Clearance to non-mechanical air supply inlet to the building or the combustion air inlet to any other appliance	12	30
K	Clearance to a mechanical air supply inlet	72	180
L	Clearance above paved sidewalk or a paved driveway located on public property <b>Note:</b> A vent must not terminate directly above a sidewalk or paved driveway, which is located between two single-family dwellings and serves both dwellings. <b>THIS DOES NOT APPLY to direct vent, non-condensing appliances in the Province of Ontario.</b>	84	210
M	Clearance under a verandah, porch, deck or balcony Only permitted if veranda, porch, deck or balcony is fully open on a minimum of 2 sides beneath the floor	12	30

Note: Local codes and regulations may require different clearances.



# Venting

## Roof Termination

### Vertical Vent Termination

Roof Pitch	Minimum "H" (feet)
Flat to 7/12	1'
Over 7/12 to 8/12	1.5'
Over 8/12 to 9/12	2'
Over 9/12 to 10/12	2.5'
Over 10/12 to 11/12	3.25'
Over 11/12 to 12/12	4'
Over 12/12 to 14/12	5'

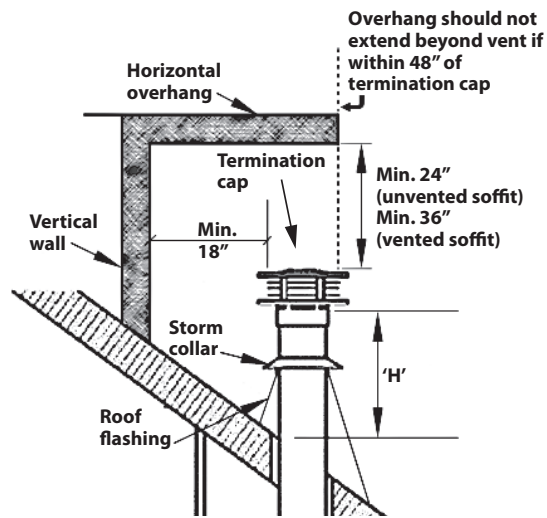

Clearance to air inlet to any other appliance is min. 12" (30 cm)

# Preparation

## **WARNING**

Please note that the HeatShift Kit **MUST** be installed on this appliance!

## **Caution**

Beware of sharp edges! Wear gloves!

### Unpack the Appliance

1. Remove the cardboard wrapping and the wood pallet from the appliance and discard.  
**DO NOT DISCARD THE PROTECTIVE CARTON AROUND THE BARRIER SCREEN!**
2. Unpack any loose items from around the appliance.
3. Verify that you have all the components required for the installation, including:
  - *approved non combustible cement board;*
  - *liners and fuel bed (in separate carton);*
  - *barrier screen;*
  - *venting components and accessories;*
  - *HeatShift Kit;*
  - *electrical components.*

### Remove Window Sill and Window

#### Remove window sill.

Lift the sill up to free the magnets underneath then pull it straight out.

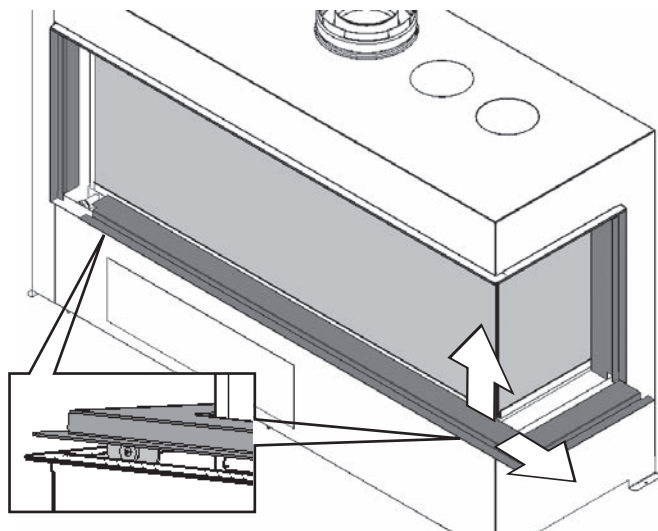

### Window Sill & Window

#### Remove the window.

1. Hook the window handle to one of the spring-loaded window levers.

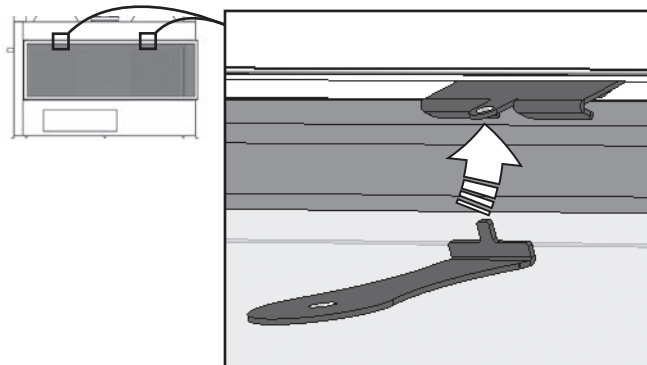

2. Pull the lever and unhook the window. Repeat with the other lever.

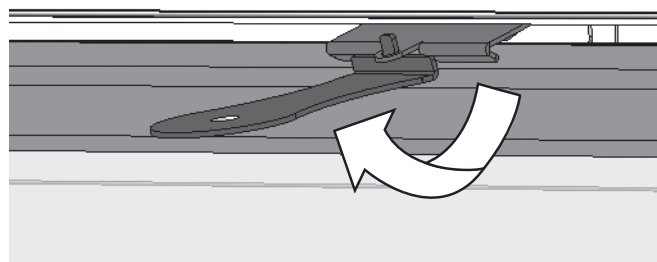

3. Pull the top of the window outward and lift it up behind the front panel to disengage it from its rail.

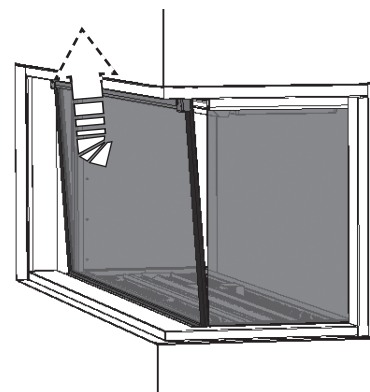

4. Once removed from the bottom rail, rotate the window pane outward to take it out completely; set it aside in a safe place to avoid damage.

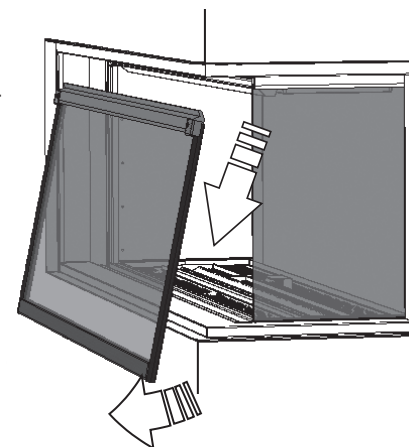

# Preparation

## Fit Standoffs

The standoffs are supplied flat. Bend them as shown and fix them to the top of the firebox.

**Note:** If installing with an all steel framing, the top standoffs are not necessary. Ensure that the framing is self-supporting, that is it NOT supported by the engine.

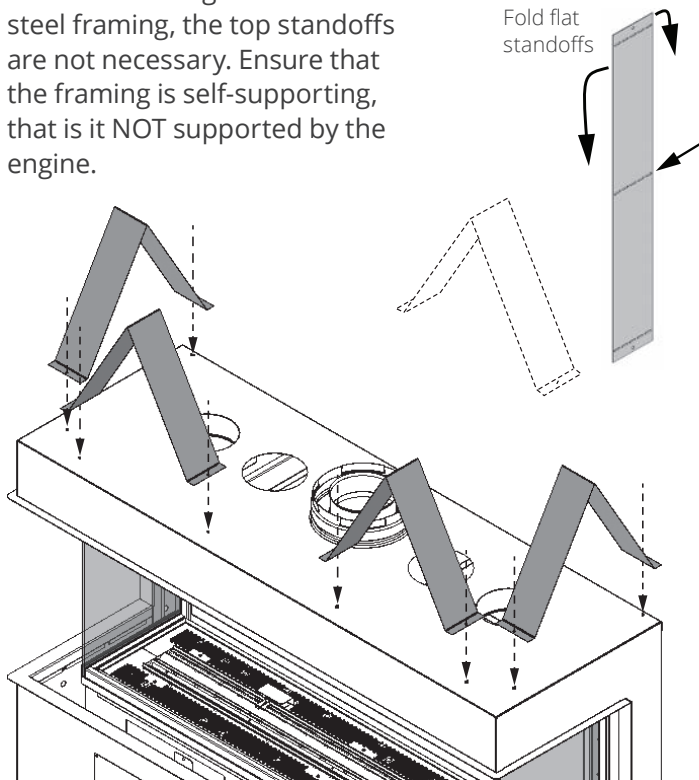

## Standoffs & Adapter

## Fit HeatShift Take-off Collars (required)

Install HeatShift take-off collars to appliance using screws provided with appliance. See HeatShift installation information in Appendix for details.

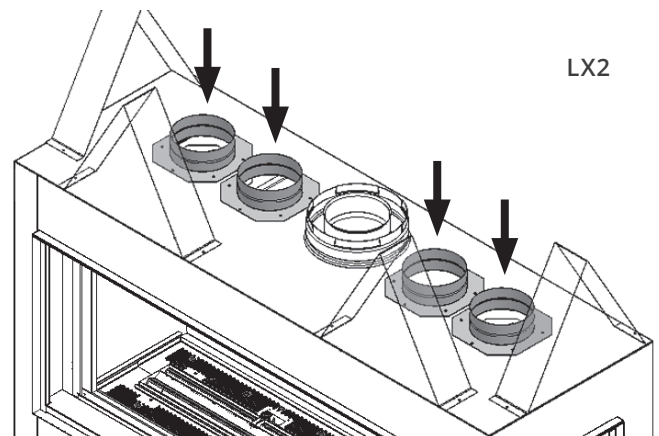

## Fit 6-5/8" x 4" Vent Adapter (if required)

This unit is supplied with a 5" x 8" vent outlet which can be field-converted to a 4" x 6-5/8" vent outlet by installing the vent adapter supplied with the appliance.

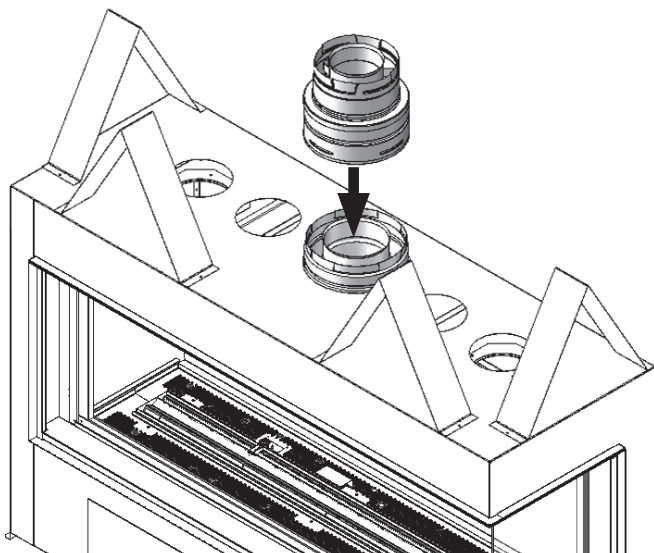

# Installation

## Electrical Wiring

### Prepare Appliance for Wiring

#### Decorative Lighting and Remote Battery & Wall Switch Kit (RBWSK)

The fireplace is equipped with a decorative lighting located above the firebed inside the firebox. The lighting is pre-wired at the factory and **must be connected to the electrical system of the home PRIOR to the final positioning of the fireplace** into the framing. The decorative lighting is operated by the fireplace's remote control handset.

Wiring for the overhead lighting and RBWSK kit is accessible from the rear panel of the appliance and therefore it should be done **BEFORE** the final positioning of the fireplace in the framing.

#### **WARNING**

**All electrical installations must be performed by a qualified electrician and must be electrically wired and grounded in accordance with local codes, or, in the absence of local codes, with the National Electrical Code, ANSI/NFPA 70 or the Canadian Electrical Code, CSA C22.1.**

The fireplace's upper decorative lighting is connected to the v-module box located behind the appliance's front panel below the window. It is hidden under the valve shield. The v-module is powered by a three-prong plug plugged into a receptacle inside the appliance case, at the rear, on the left-hand side.

1. At the back of the fireplace case, on the left-hand side, remove the electrical box cover (4 screws).

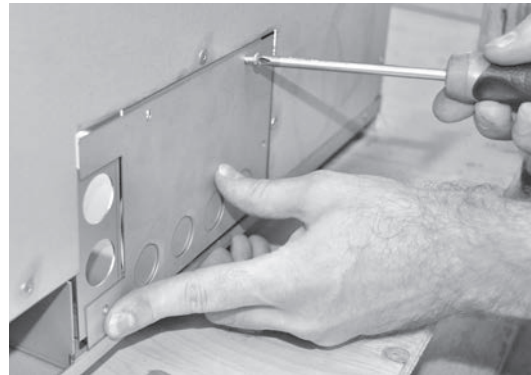
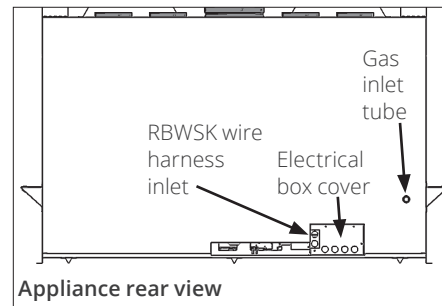

2. Remove a knock-out cover for the electrical connection needed for incoming power.
3. Rough in the wiring harness for the RBWSK—Remote Battery & Wall Switch Kit. Thread through one of the holes to the left of the electrical panel both the power connector and the white connector end of the wire harness to reach the receiver at the front of the appliance, about 3 feet (36 cm).

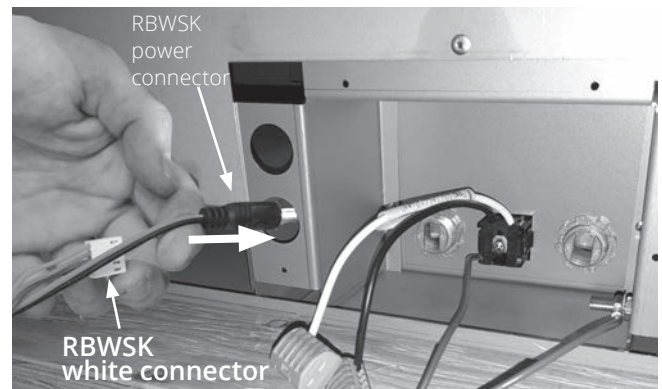

4. Refit the electrical box cover.

# Installation

## Gas Supply

5. Remove the 4 screws retaining the appliance to its pallet. Snap off the feet attached to the pallet and discard or recycle.

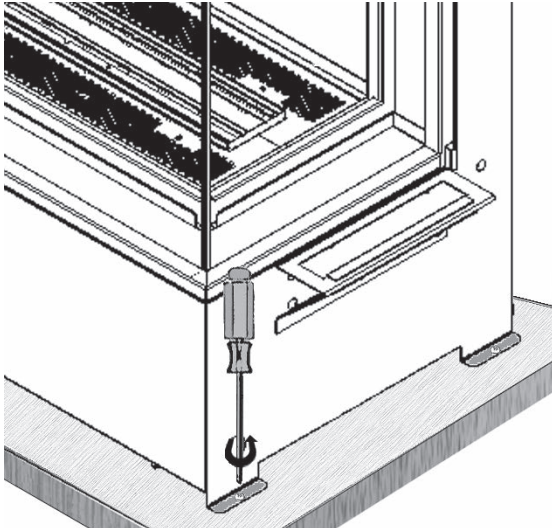

6. With great care not to cut yourself on the sharp feet, set the appliance partially into the framing keeping in mind the need to access the rear of the appliance to connect the electrical wires.

### Set-up Gas Supply

The gas supply inlet connection is a 1/2" NPT male line stub located on the rear left hand side of the appliance.

The unit is supplied with a stainless steel flex line to allow the appliance to be disconnected for service. An individual shut-off valve (supplied) is required on the supply line ahead of the flex connector.

Use only new black iron or steel pipes, CSST, or copper tubing if acceptable—check local codes. Note that in USA, copper tubing must be internally tinned for protection against sulfur compounds.

Unions in gas lines should be of ground joint type.

The gas supply line must be sized and installed to provide a supply of gas sufficient to meet the maximum demand of the appliance without undue loss of pressure.

Sealant used must be resistant to the action of all gas constituents including LP gas. Sealant should be applied lightly to male threads to ensure excess sealant does not enter gas lines.

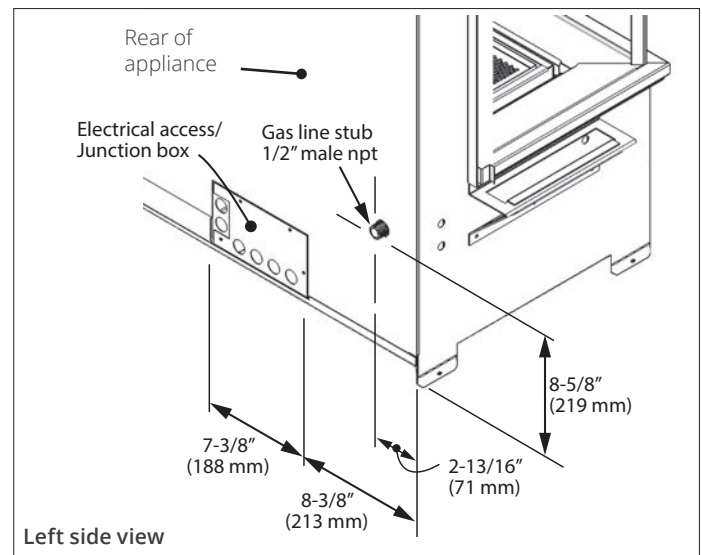
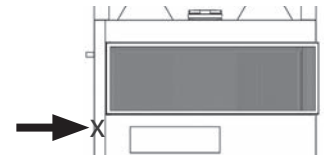

# Installation

## Gas Supply

### Pressure test the supply line for leaks.

The appliance and its individual shut-off valve must be disconnected from the gas supply piping system during any pressure testing of that system at test pressures in excess of 1/2 psig (3.5 kPa).

The appliance must be isolated from the gas supply piping system by closing its individual manual shut-off valve during any pressure testing of the gas supply piping system at test pressures equal to or less than 1/2 psig (3.5 kPa).

Failure to either disconnect or isolate the appliance during pressure testing may result in regulator or valve damages and void the warranty. Consult your dealer in case of damages.

### Pressure Test Points

The minimum supply pressure is given in the section "Specifications" on page 6.

All piping and connections must be tested for leaks after installation or servicing. All leaks must be corrected immediately.

When testing for leaks:

- Make sure that the appliance is turned off.
- Open the manual shut-off valve.
- Test for leaks by applying a liquid detergent or soap solution to all joints. Bubbles forming indicate a gas leak.

### **WARNING**

**Never use an open flame to check for leaks. Correct any leak detected immediately.**

The pressure test tapping locations are shown in the figure below. An internal regulator within the valve controls the burner manifold pressure.

The correct pressure range is shown in the table in section "Specifications" on page 6.

The pressure check should be made with the burner alight and at its highest setting. See "Appendix A - Lighting Instructions Plate"

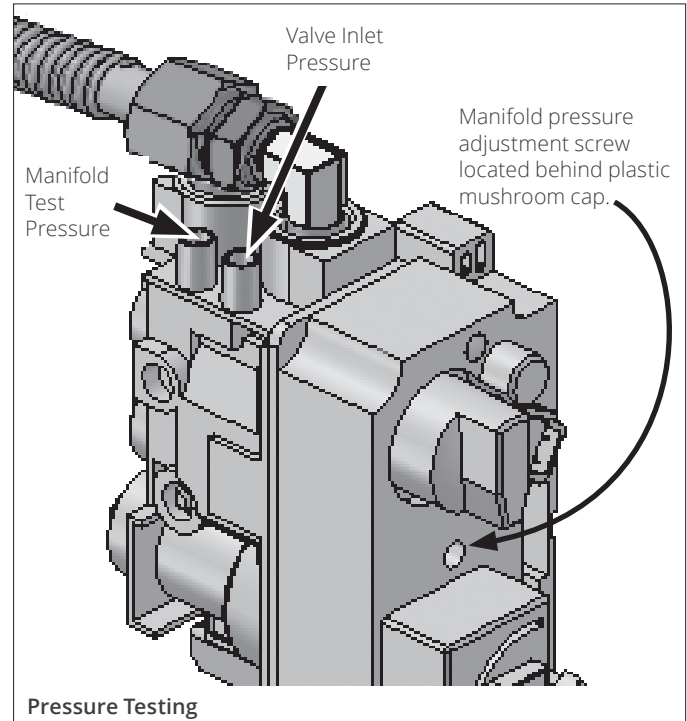

### Place the appliance in final position

1. Taking great care not to cut your hands on the sheet metal edges, place the appliance in its final position in the framing. *Make sure that the unit is at the right height with consideration to the height of the hearth or combustible flooring.*
2. Remove carrying handles on both side.

### Complete Installation of HeatShift Kit (required)

See "Appendix D - HeatShift System" on page 72.

# Installation

## Install Remote Battery and Wall Switch Kit RBWSK (required)

The Remote Battery and Wall Switch Kit is provided with this appliance. It must be connected to the receiver in the fireplace.

### Caution

Do not put batteries in the receiver as they will overheat and possibly leak causing the system to stop functioning.

### Material required

- 4 AA 1.5V alkaline batteries supplied with the engine
- Remote Battery and Wall Switch Kit, which contains:
  - 1 Wall Switch
  - 2 Screws
  - 1 Battery Holder
  - 1 Plate with magnets
  - 1 Battery Cover assembly
  - 1 Harness assembly - 35 ft
  - 1 Junction Box
  - 1 Cover plate and Screws
  - 1 Cable tie

### Installation

The receiver is located behind the appliance's front panel, at the right of the control valve. It is maintained in position with *Velcro* bands.

1. From the front of the appliance through the access panel, grab the wire harness threaded from the back and bring it towards the receiver at the front of the appliance.
2. Pull out the receiver from its location to connect the wiring harness power connector to receiver's jack.



## Remote Battery & Wall Switch Kit

### Caution

Do not run the switch wire over the top of the firebox. Route the wire so it does not contact the firebox.

3. Connect the harness' white connector to the auxiliary 5-pin junction on the receiver.

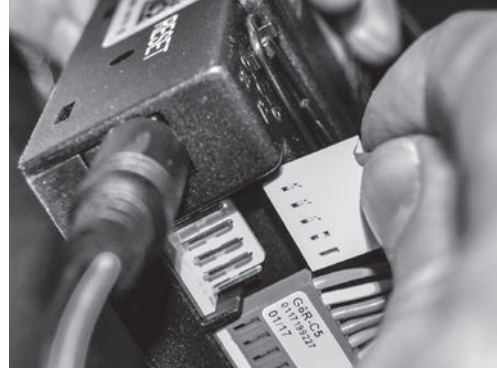

4. Run the harness assembly to the mounted position of the junction box, securing the harness to the framing using insulated staples (not supplied).
5. Feed the harness assembly through a restrain on the rear of the junction box, feeding through until the harness sheath is pinched by the retainer and ensuring sufficient length to make the connection to the rear of the switch and battery holder.



6. Secure the junction box to the mounting surface using appropriate fasteners (not supplied).

# Installation

## Remote Battery & Wall Switch Kit

7. Align the mox connection on the switch cable of the harness assembly and connect to switch.

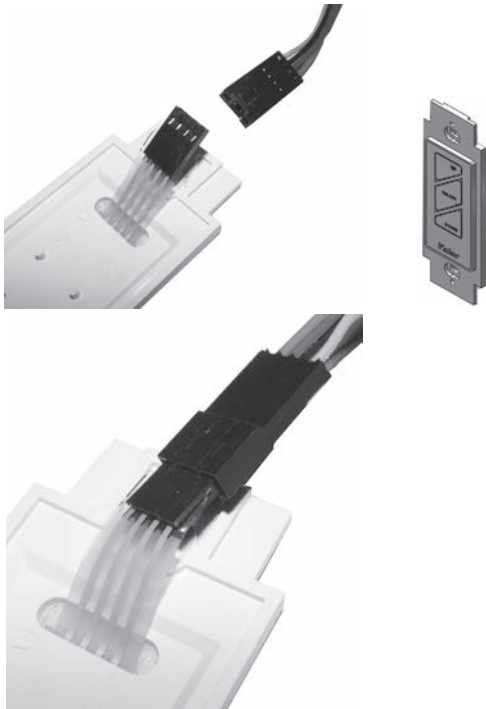

8. Mount the switch plate to the junction box with 2 screws provided. Note: Place the switch left or right to suit the homeowner wishes.

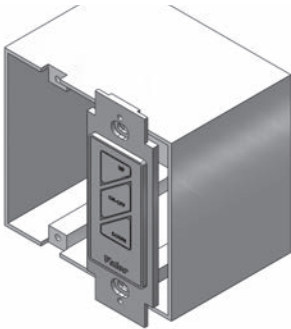

9. Locate and secure the magnet plates using 2 'long' screws provided.

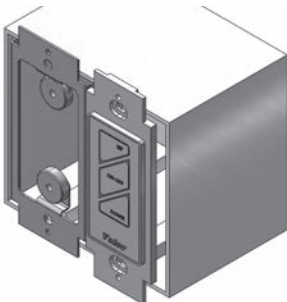

10. Place and secure the cover plate to the box using 4 screws provided.

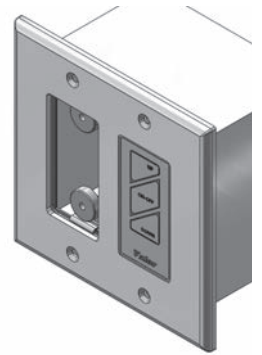

11. Feed the cable tie through the 2 side slots of the battery cover assembly.
12. Position the battery holder to the rear face and secure together with a cable tie. Note that clearance is required for battery snap connection.

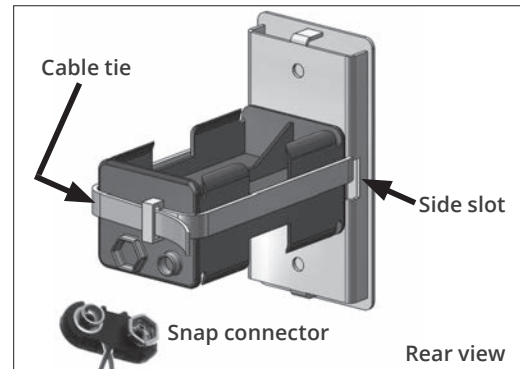

13. Make the snap connection, load 4 AA alkaline batteries into the holder (included with fireplace) then feed back into the junction box assembly. Note: Do not put batteries in the receiver, only in the battery holder by the wall switch.

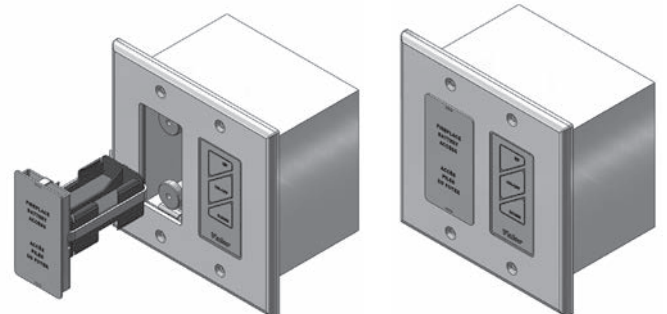
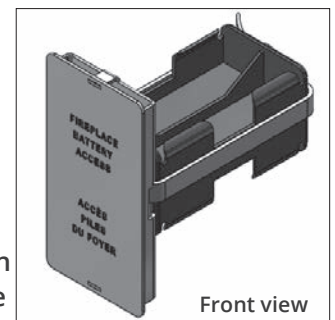

14. Test the operation of the wall switch—see Appendix.



# Installation

## WiFi Module (optional)

### WiFi Module (Optional)

If ordered, the WiFi module (part number GV60WIFI) will require synchronization and setup to allow the fireplace to operate on the homeowner's network.

See the literature that accompanies the WiFi module kit for instructions to install and set up. See also "107" on page 92.

**Note:** The homeowner will either need to be present for installation or leave their WiFi password for the installer to use during setup. Otherwise the installer can complete the physical installation and leave the remaining setup instructions for the homeowner.



# Installation

## Liners

### Liners

**Ceramic Liners:** The ceramic liner panels consist of three rear sections in one carton and one end panel in a separate carton. The three sections are fitted into each other. Two of the sections are identical. Their step edges go towards the middle to fit into the middle section.

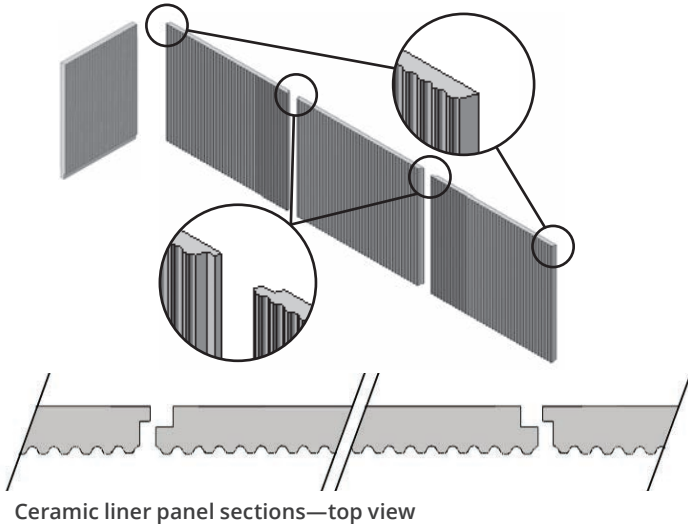

**Glass Liners:** The glass liner panels consist of three identical rear sections in one carton and one end panel in a separate carton.

The Glass Liners install in the same manner and order as the ceramic panels; however they don't fit into each other. They sit beside each other.

### Installation

1. Unpack the liner panels carefully.
2. Remove the rear media tray (3 screws).

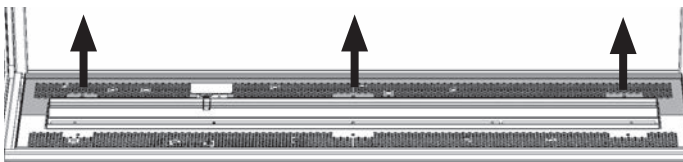

3. Inside the firebox, at the rear of the top panel, and on the closed side of the firebox, release the screw of the 4 panel supports and slide the supports towards the middle of the firebox.

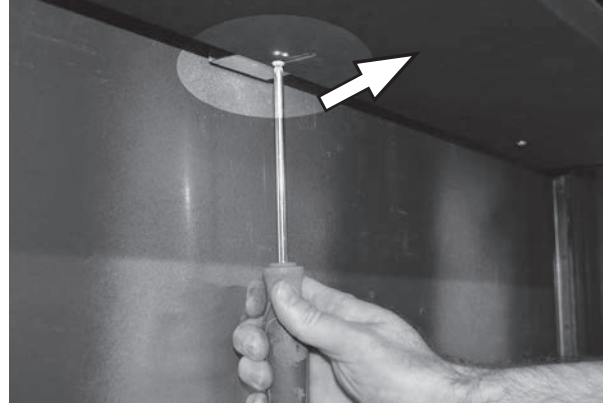

4. Place the end panel, notch at the top, against the side wall of the firebox and rest it on the ledge. Slide the panel towards the front of the firebox.

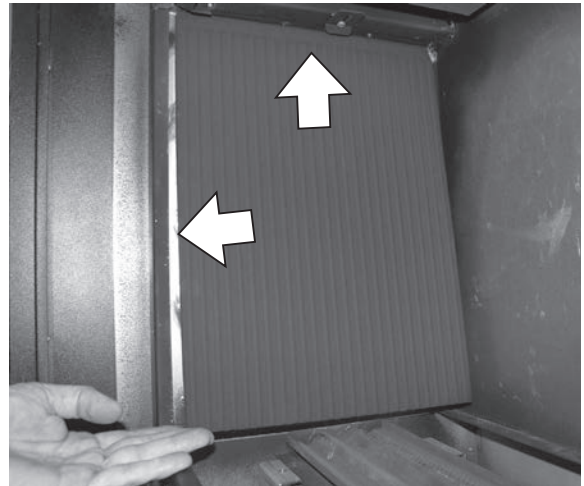

5. Place one rear end panel, top first, against the back wall of the firebox, square edge outward and step edge in the center. Slide the panel outward so it is held behind the mounting support.

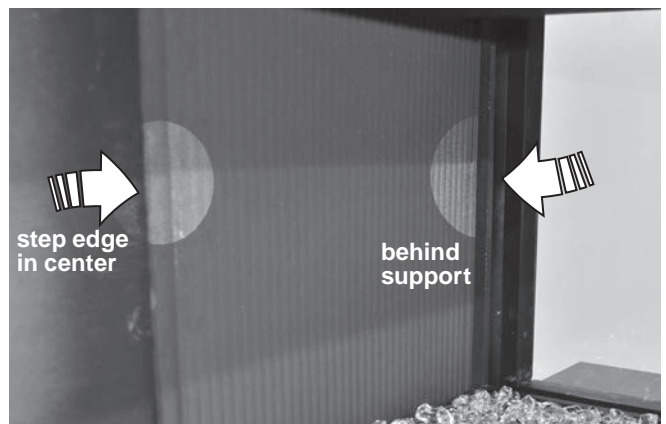

# Installation

## Liners

6. Repeat with the other end panel.
7. Fit the center panel with its step edges overlapping both end panels.



8. Slide the end panels towards the center and slide the firebox end panel against the rear to eliminate any gaps between them.

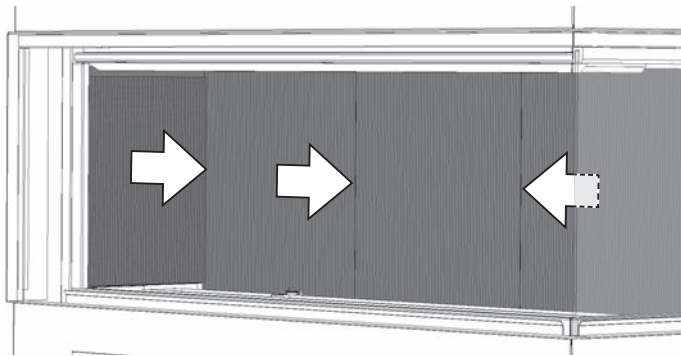

9. Ensure all panels are square against the back wall of the firebox.
10. Push the 3 panel supports against the top of each section and tighten the screw.

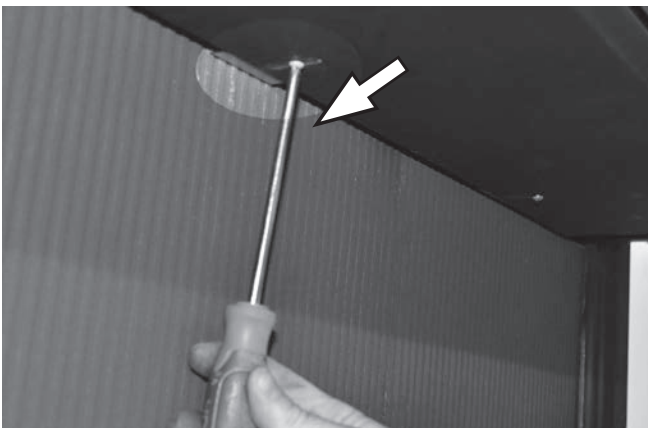

11. Two brick retainers and three glass retainers are supplied with the panels. They are used to hold the bottom of the rear panels against the rear wall of the firebox. The brick retainers have a shallower return and the glass retainers have a deeper return.

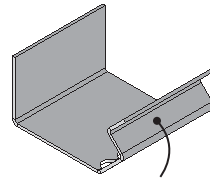

Brick retainer with a shallower return

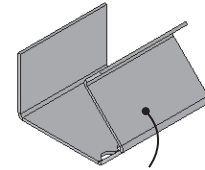

Glass retainer with a deeper return

12. Hook one retainer to the back of the firebox rear wall and fold it over the lip on which sits the ceramic panel so it holds the panel against the rear wall.

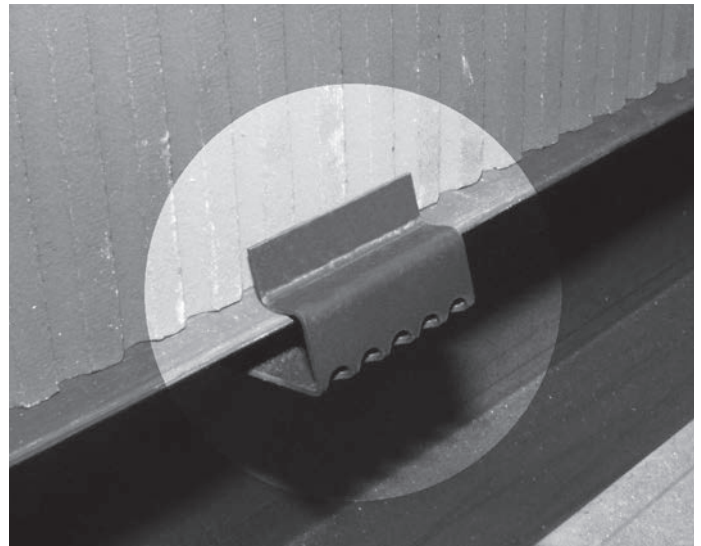
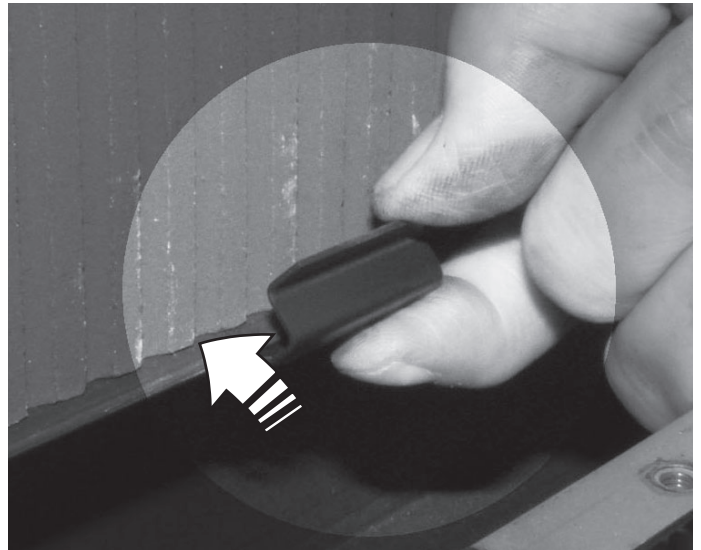

13. Repeat with the other panels.
14. Re-install the rear media tray (3 screws).

# Installation

## Fuel Beds

### Birch Log Kit 1700BLK

#### Material required

- Birch Log Kit, which contains:
  - 9 logs

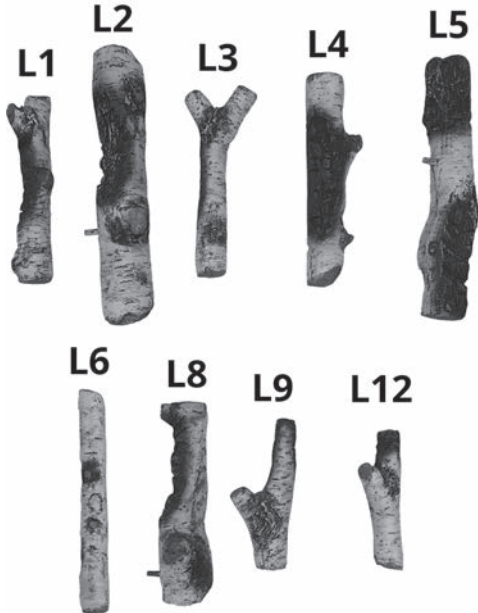

- 1 bag of mixed grey embers (8 cup bag)



- 1 bag of splinters



Carefully unpack the kit, as the logs are fragile.

#### Installation

1. Place log L2 with pin inserted as shown.

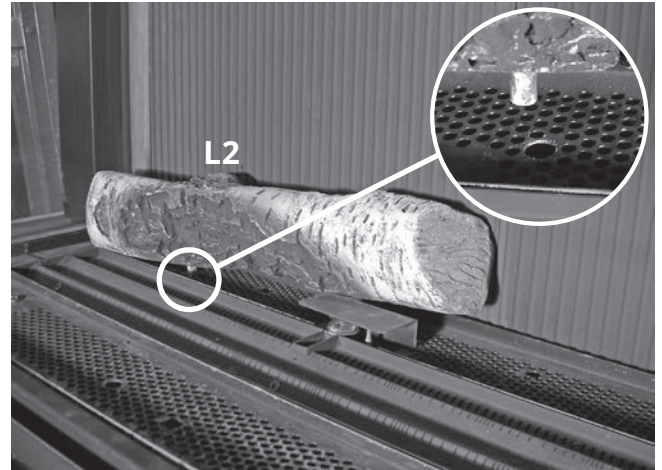

2. Place log L1 from the left end of L2 and across the burner to rest on the media tray as shown.

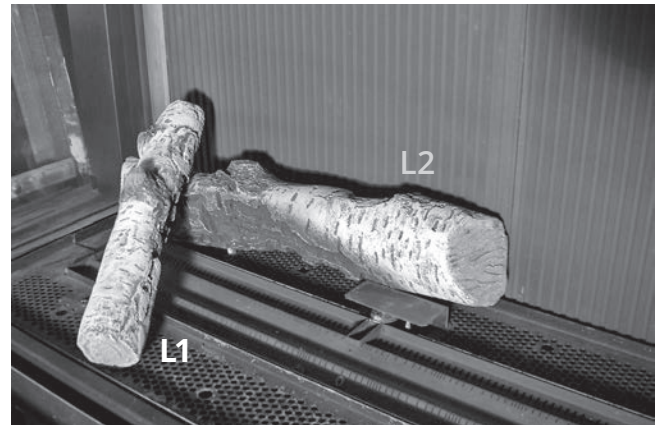

3. Place log L12 on the media tray near the end of L1, and onto the side of the burner.

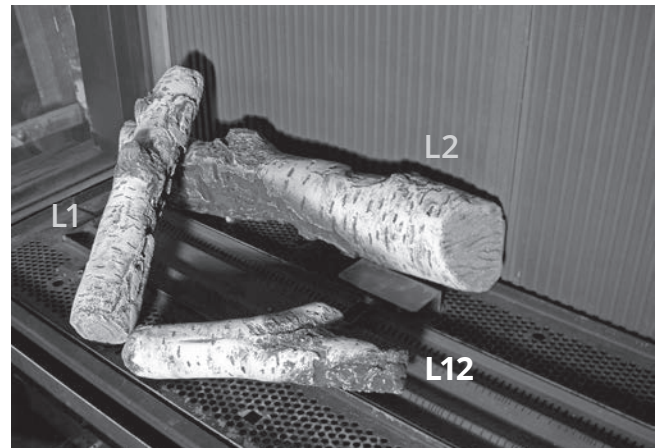

# Installation

## Fuel Beds

- Place log L5 on the rear media tray with pin inserted as shown.

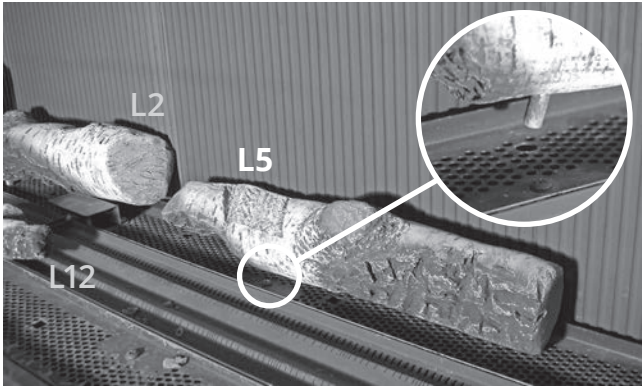

- Place log L4 from the left end of L5 and across the burner to rest on the media tray as shown.

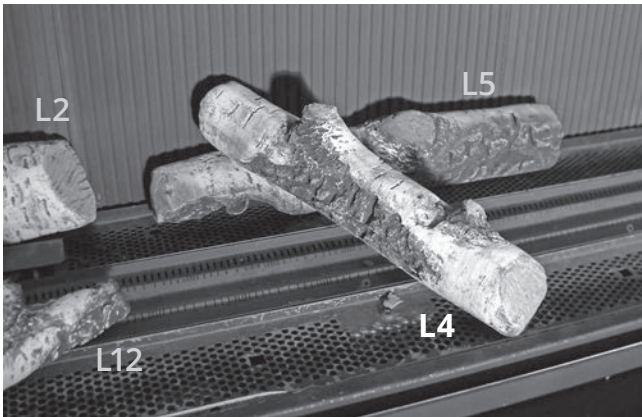

- Place log L6 from the top of L5 onto the front of the media tray as shown.

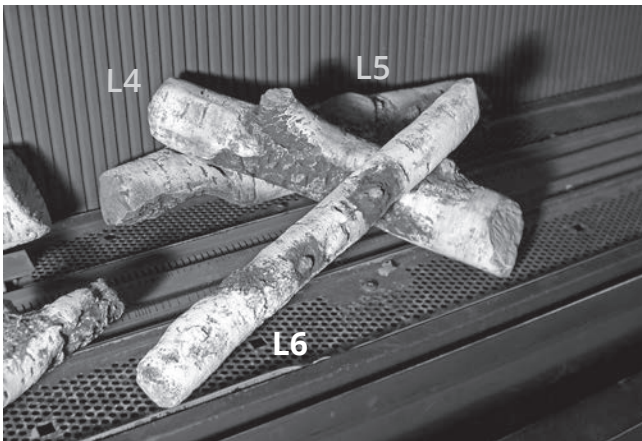

- Remove and discard the pin from log L8.

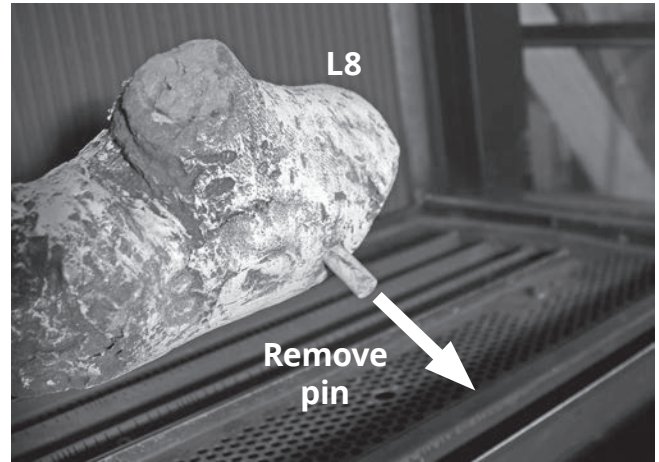

- Place log L8 across the burner at the right end of the fireplace as shown.

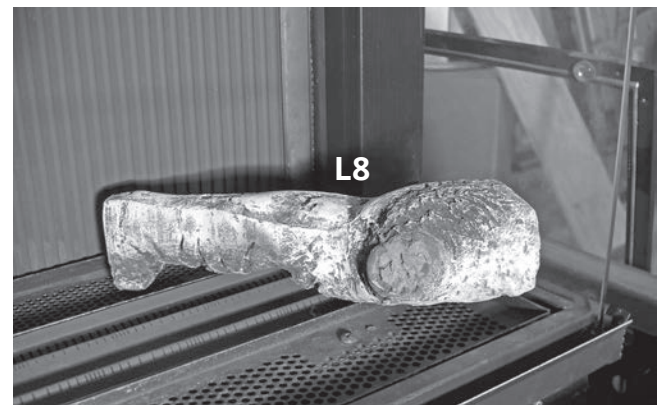

- Place log L3 on top of L8 to the front of the media tray as shown.

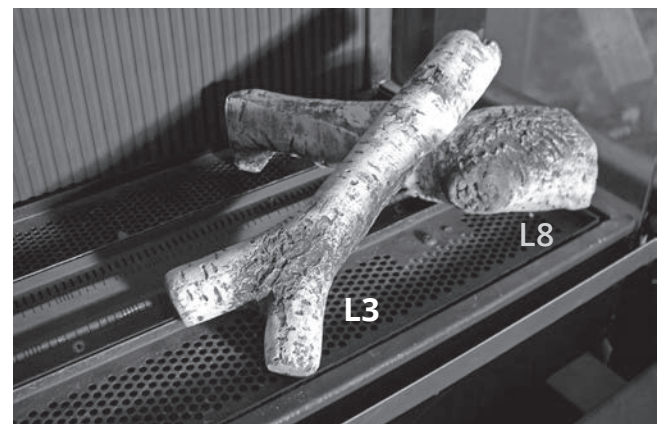

# Installation

## Fuel Beds

10. Place log L9 on the rear media tray and up onto the edge of the burner as shown.

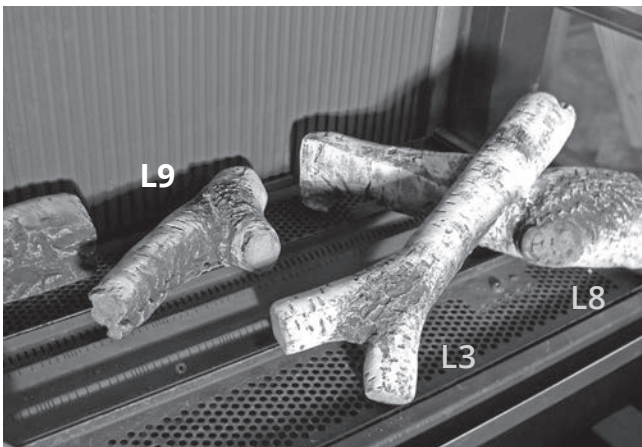

11. Place embers by hand onto the media tray and burner. Do not pour embers, as dust could block burner ports. Place splinters among embers when complete.



### **WARNING**

**CHOKING HAZARD!** Ensure that the fireplace area is clear of ember and splinter particles as these could be ingested by small children. Vacuum area after installation.

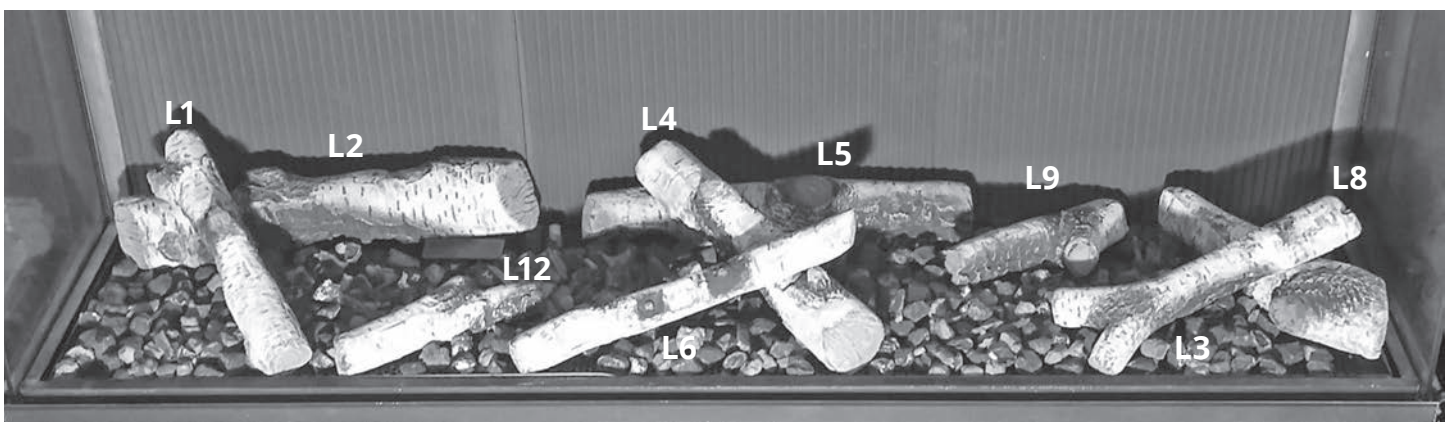

Birch Log Kit installed

# Installation

## Fuel Beds

### Long Beach Driftwood 1705DWK

#### Material required

- Long Beach Driftwood Kit, which contains:
  - 6 logs
  - 10 pebbles
  - 1 bag of vermiculite

#### Installation

##### Vermiculite

Carefully unpack the kit.

1. Carefully spread vermiculite by hand on the surface of burner only, forming a single layer to the approximate level of the top of the flange at the edge of the burner. Do not pour from the bag and do not pour too much to avoid blocking the burner ports.



**NOTE:** Ensure the area within the pilot shield is clear of vermiculite. Some vermiculite can be deposited into the pilot safe zone.

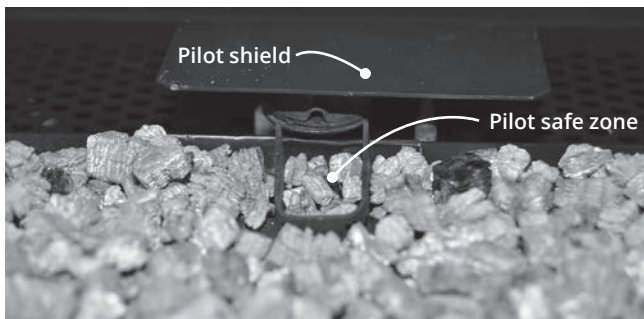

##### Logs and rocks

Each log has pegs to help you locate it on the media tray. Install the logs as shown below using the **round holes**.

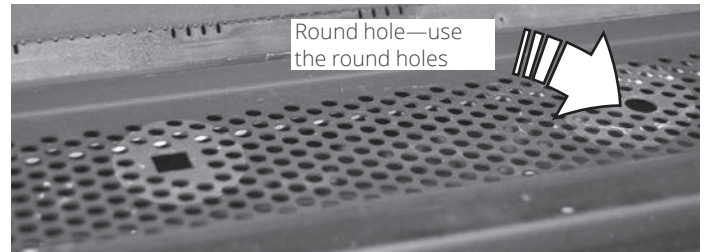

1. Place the rear left log at the left end of the media tray as indicated. Its narrow end rests on the vermiculite as indicated.

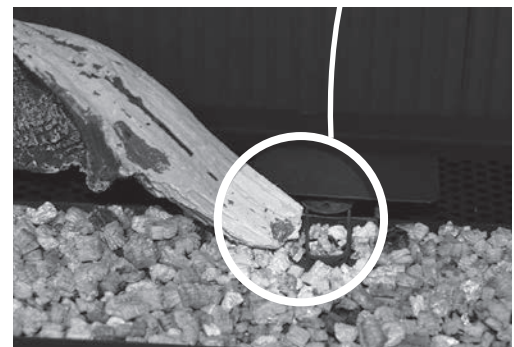
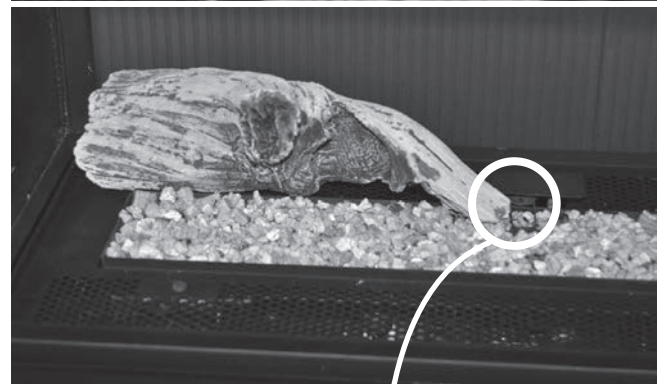
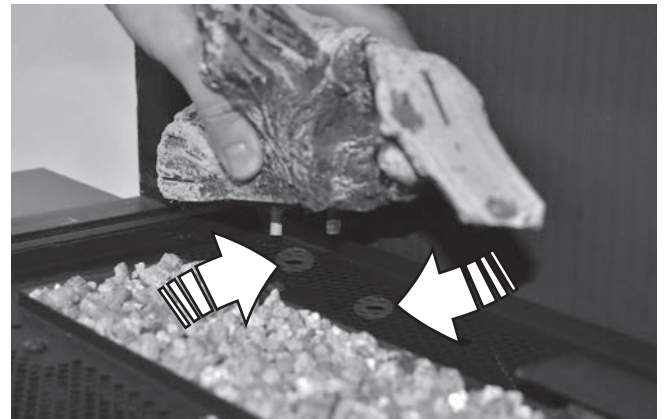

# Installation

## Fuel Beds

2. Place the front left log as indicated.



3. Place the center rear log as indicated.

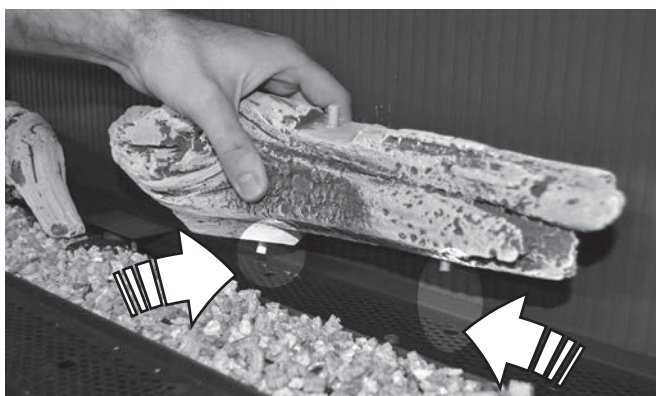

4. Add some vermiculite in the media tray at the right end of the burner and behind as indicated. This vermiculite will help keep the right rear log in position.

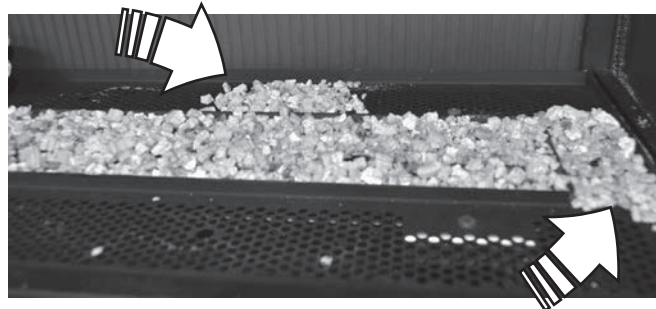

5. Place the right rear log as indicated. The small end of the log rests on the burner, 1-3/4 inch from the front edge of the burner.

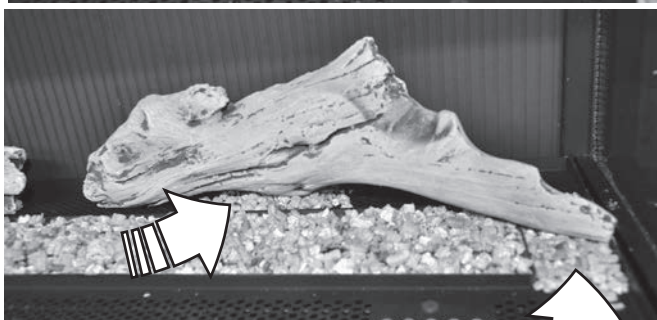

6. Place the right cross log on to recess of right rear log as indicated, ensuring it is firmly located.

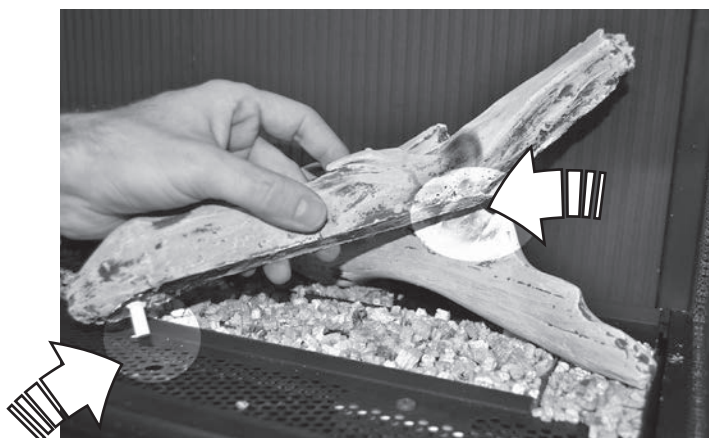



# Installation

## Fuel Beds



7. Lightly rotate forward the center rear log and place the centre cross log onto the rear log as indicated. .

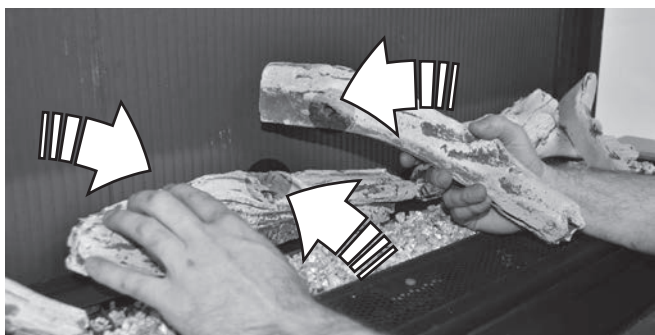

8. Vermiculite may be added outside the burner on the platform if desired around the logs.



9. Place the rocks on the platform as shown below.

### **WARNING**

**CHOKING HAZARD!** Ensure that the fireplace area is clear of vermiculite particles as these could be ingested by small children. Vacuum area after installation.



Long Beach Driftwood Kit installed

# Installation

## Fuel Beds

### Decorative Glass Murano 2200DGM

#### Material required

- Decorative Glass Murano kit, which contains:
  - 1 bag of clear fireglass
  - 2-piece glass platform
  - 8 ceramic pads

#### Installation

Carefully unpack the kit.

1. Install the 8 ceramic pads around the burner as indicated. The pads will raise the glass platform.



2. Install the front and rear glass platform, smooth side up, on the ceramic pads.

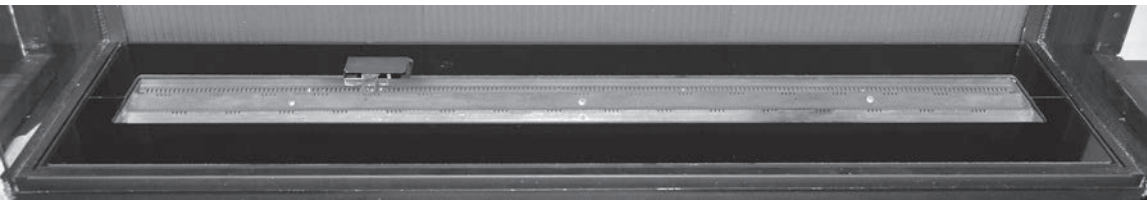

3. Carefully spread the fireglass by hand on the surface of burner forming a single layer to the level of the top edge of the flange around the burner. Do not pour directly from the bag and do not pour too much to avoid blocking the burner ports.

**NOTE:** Ensure the areas *within* the pilot shield and pilot safe zone are clear of fireglass.

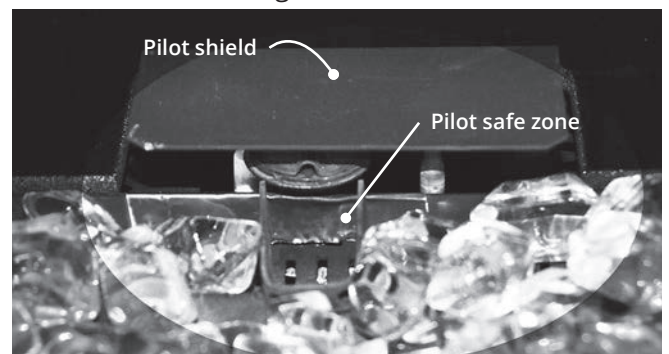

Decorative Glass Murano installed

#### **WARNING**

**CHOKING HAZARD!** Ensure that the fireplace area is clear of fireglass particles as these could be ingested by small children. Vacuum area after installation.

**IMPORTANT:** Approved for use only with the fireglass provided with your Valor fireplace. The use of any other fireglass products may void your fireplace warranty.

# Installation

## Fuel Beds

### Decorative Glass Set 2200DGS

#### Material required

- Decorative Glass set, which contains:
  - 4 bags of clear fireglass

#### Installation

Carefully unpack the kit.

Carefully spread the fireglass by hand on the surface of burner and the media tray covering the edge of the burner. **Do not pour directly from the bag and do not pour too much to avoid blocking the burner ports.**

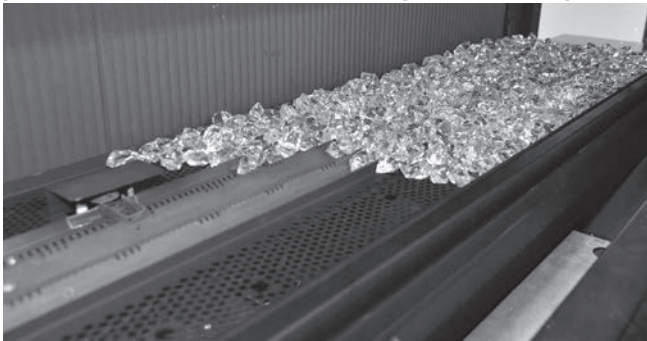

Use one bag of fireglass for the burner, one for the rear media tray and one for the front media tray. Use the fourth bag to fill up gaps or edges of the burner.

**NOTE:** Ensure the areas **within** the pilot shield and pilot safe zone are clear of fireglass.

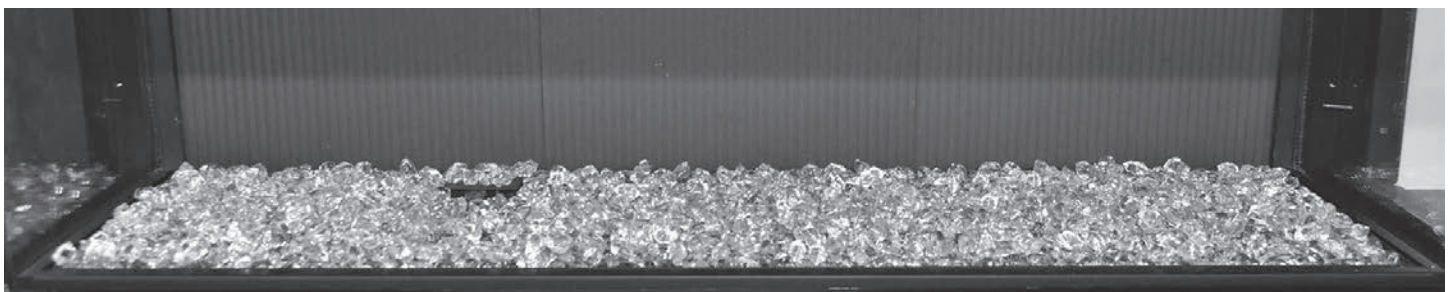
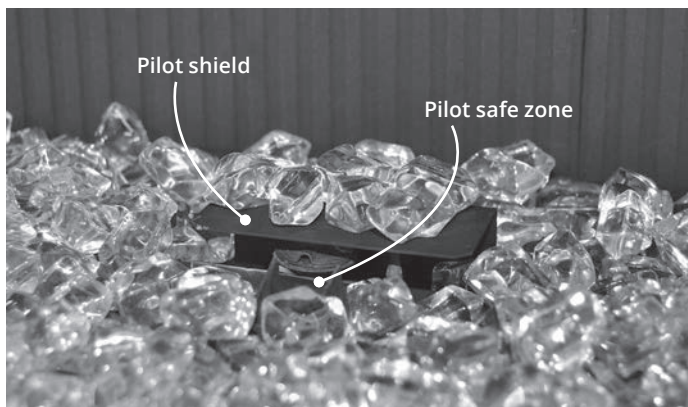

Decorative Glass Set installed

#### **WARNING**

**CHOKING HAZARD! Ensure that the fireplace area is clear of fireglass particles as these could be ingested by small children. Vacuum area after installation.**

**IMPORTANT:** Approved for use only with the fireglass provided with your Valor fireplace. The use of any other fireglass products may void your fireplace warranty.

# Installation

## Fuel Beds

### Splitwood Kit 1700SWK

#### Material required

- Split Wood Kit, which contains:
  - 1 bag of splinters
  - 1 bag of small embers
  - 11 logs

#### Installation

Carefully unpack the kit.

#### Logs, embers & splinters

Some logs are marked with a number to facilitate their identification. They also have positioning pins underneath which fit into the SQUARE holes in the media tray.

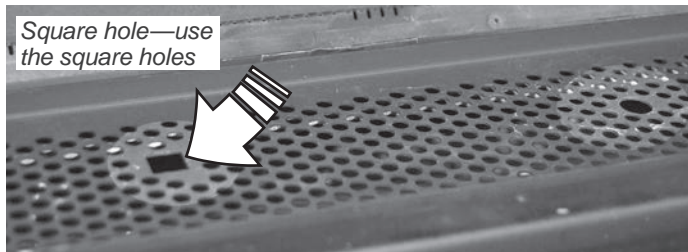

Some logs straddle the burner; make sure they rest over the smaller burner ports rather than the larger ones.

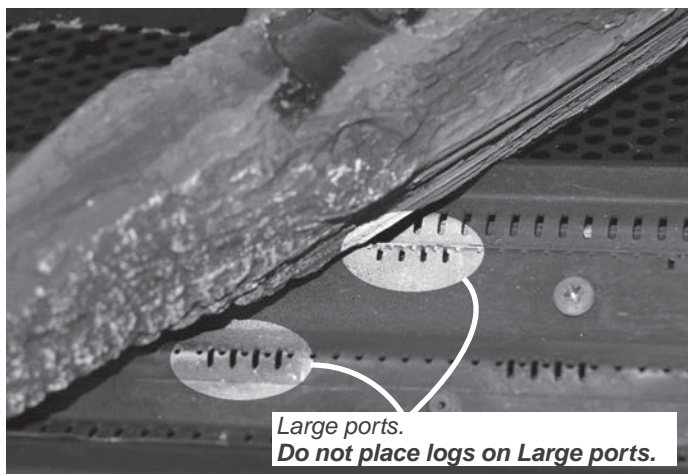

1. Install the logs according to the images below. See image of full layout of logs in the following pages. Use the following order: log 1, 2, 3, 4, 6, 5, 7, 9, 8, 10 and 11.

#### Notes

- Log 1 rests on the media tray.



- Log 2 rests on notch of log 1.



- Log 3 rests across the front corner of the burner.

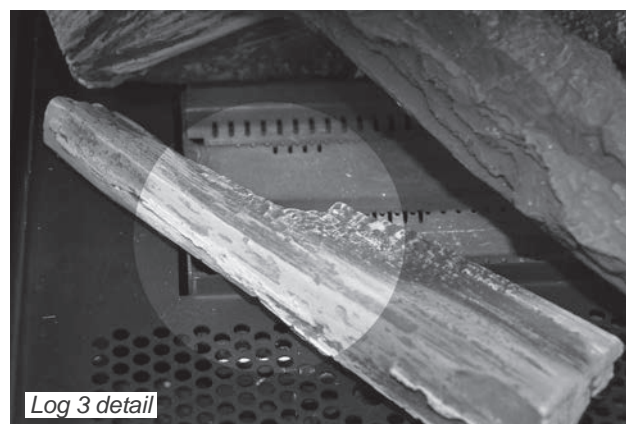

# Installation

## Fuel Beds

- Log 4 straddles the burner, rests on two pieces of ember—do not cover the large burner ports.

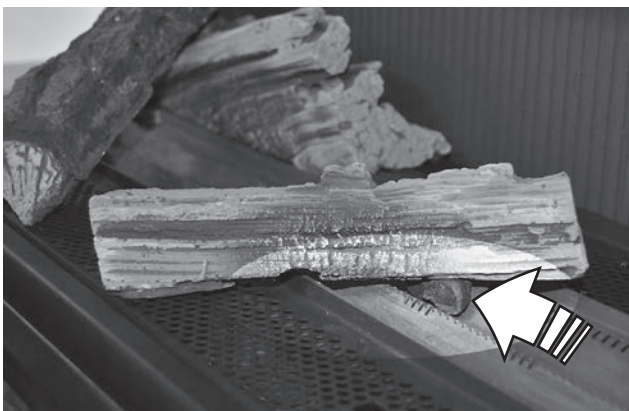

- Log 6 straddles the burner—do not cover the large burner ports.
- Log 5 rests on rear notch of log 6.

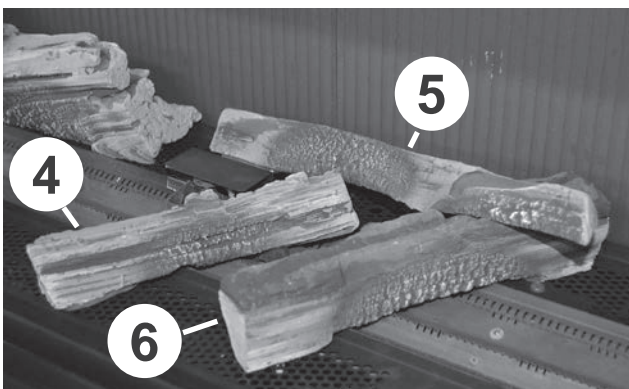

- Log 7 rests on front notch of log 6.



- Log 9 straddles the burner—do not cover the large burner ports.



- Log 8 rests on the notch of log 9.

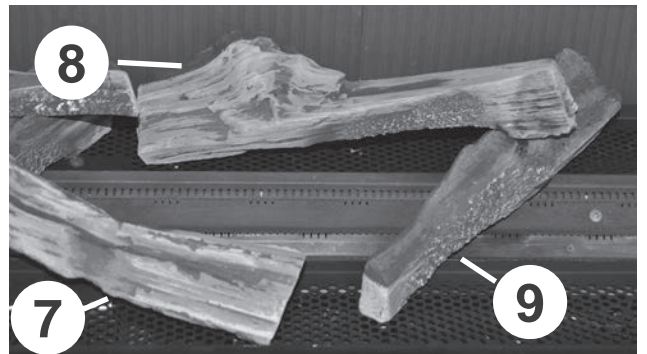

# Installation

## Fuel Beds

- Log 10 rests on the rear and the right edge of the media tray wrapping around the corner of the burner. Note: the right side of the log does NOT touch the window.

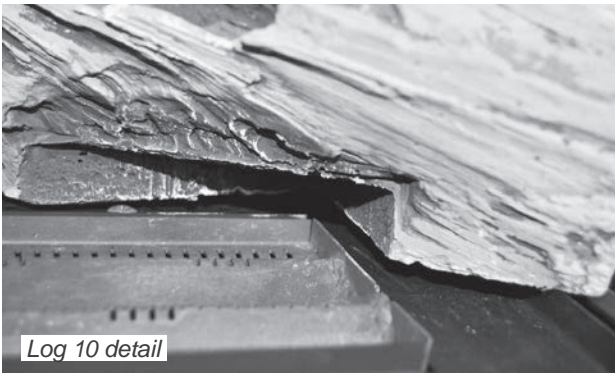

- Log 11 rests on notch of log 10.



# Installation

## Fuel Beds

Logs installed—full layout

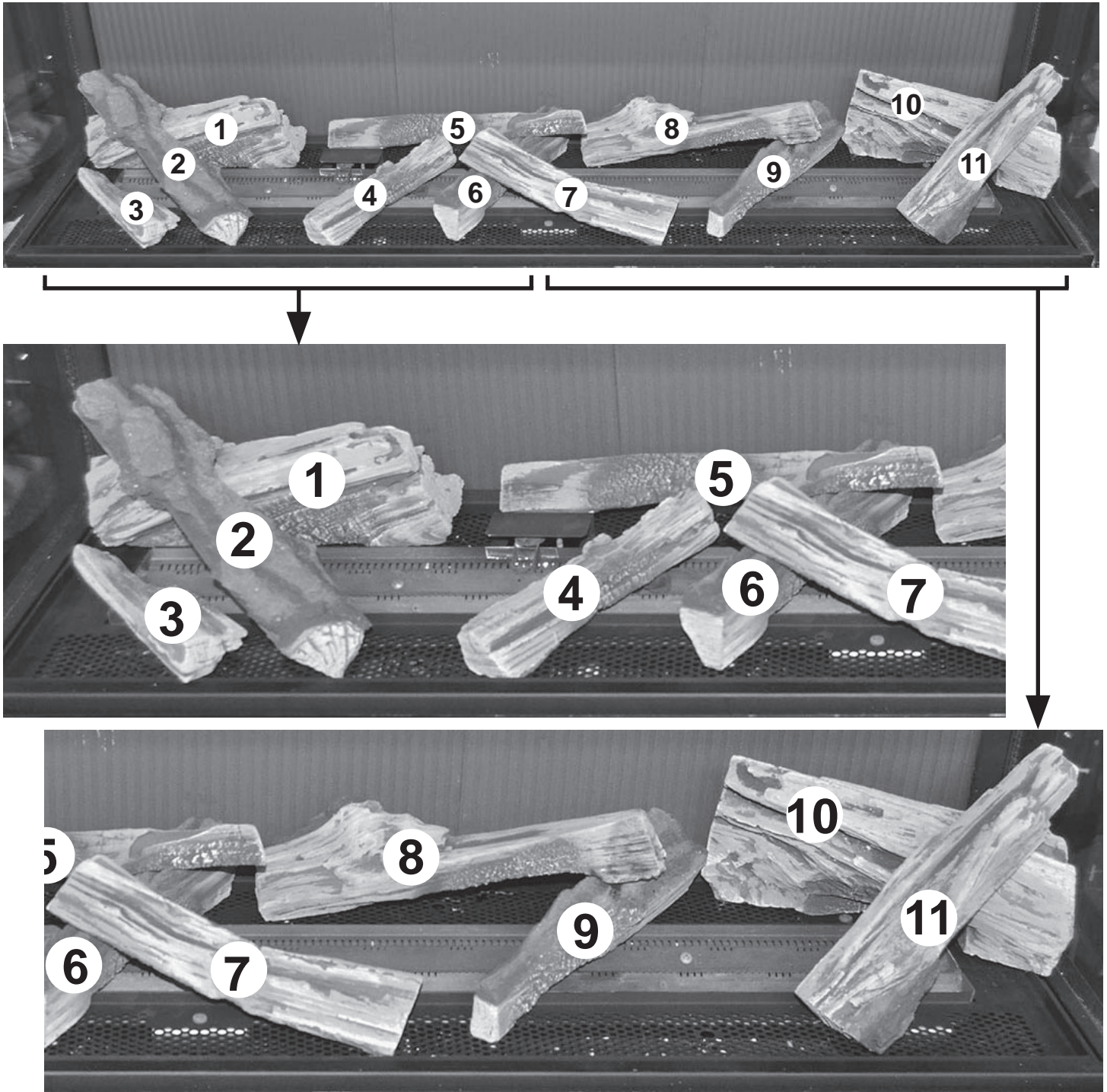

# Installation

## Fuel Beds

- Carefully spread by hand the embers loosely in a single layer on the surface around the logs. Do not pour from the bag neither pile up the embers to avoid blocking the burner ports.



- Use the embers to cover the edge of the burner and the round holes.

- Spread some splinters to the embers.  
**NOTE:** Ensure the areas *within* the pilot shield and pilot safe zone are clear of embers or splinters.

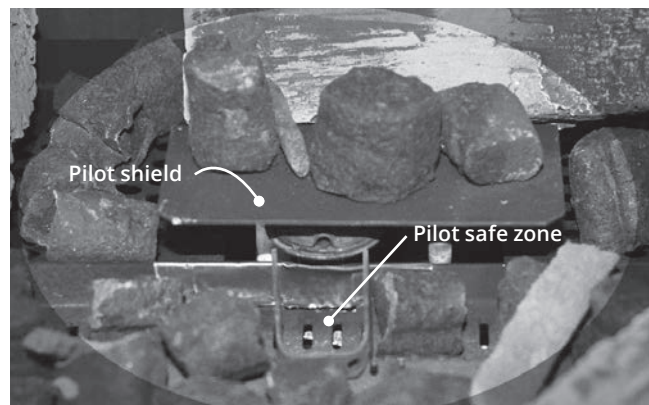

### **WARNING**

**CHOKING HAZARD!** Ensure that the fireplace area is clear of embers/splinters particles as these could be ingested by small children. Vacuum area after installation.

**IMPORTANT:** Approved for use only with the ceramic embers and splinters provided with your Valor fireplace. The use of any other products may void your fireplace warranty.



1700SWK installed



# Installation

## Fuel Beds

### Rocks & Shale Set 1714RSS

#### Material required

- Rock & Shale Set, which contains:
  - 1/2lb-bag of 3/4" grey shale
  - 1/2lb-bag of 3/4" black shale
  - 5 twigs
  - 34 rocks

#### Installation

Carefully unpack the kit.

1. Mix the black and grey shale pieces and spread them by hand in one layer thick on top of the burner. Do not pour from the bag and do not overfill to avoid blocking burner ports!



**NOTE:** Ensure the areas *within* the pilot shield, on the pilot shield and in pilot safe zone are clear of shale. Do not put rocks on the pilot shield!

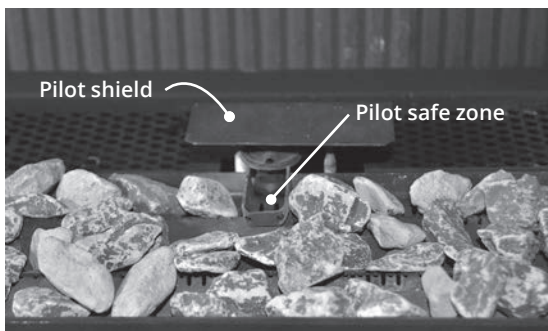

2. Place rocks around the shale bed as indicated. These rocks will be used to support the twigs. The rocks used is not important.



3. Place the twigs on the rocks as shown.  
**Note:** The position of the twigs are specific to obtain the best flame pattern. The twigs should not rest flat on the shale bed. Their position across the shale bed allows some air underneath.

  - a. Place the one of the curvy twigs as indicated.



- b. Place a short Y twig on the rocks behind the pilot shield; rest the other end on the shale bed.



# Installation

## Fuel Beds

c. Place the long Y twig as indicated.



d. Place the other short Y twig as indicated.



e. Place the other curvy twig as indicated.



### **WARNING**

**CHOKING HAZARD!** Ensure that the fireplace area is clear of shale pieces as these could be ingested by small children. Vacuum area after installation.

**IMPORTANT:** Approved for use only with the ceramic rocks, twigs and shale provided with your Valor fireplace. The use of any other products may void your fireplace warranty.

4. Install the remaining rocks around the shale bed.  
Do not put any rock on the pilot shield! Do not put rocks on the shale!  
The acceptable variations are only for rocks installed outside of the shale bed.

Suggested positions for additional rocks around shale bed



# Installation

## Replacing Light Bulbs

### Lighting

This appliance is equipped with decorative lighting located above the fuel bed.

Test this overhead lighting before completing installation (see "Appendix B - Remote Control Operation" on page 66). If any of the bulbs are out, replace them using the following steps.

### Required Bulbs

The light bulbs in the LX2 are 120V, 20W bi-pin (JC) halogen bulbs GY6.35. A total of 3 are installed in the unit.



### Remove Barriers and Windows

Changing the light bulbs requires access to the inner firebox. See "Window Sill & Window" on page 26 for details on removing the windows from the fireplace.

### Change Bulbs



**Wear gloves when changing these bulbs. Most manufacturers recommend never touching them as oil from your skin can shorten their life.**

1. Gently pull the bulb out of the receptacle in the lighting rail.
2. Replace with a new bulb. Be careful to align pins with the receptacle holes.
3. Test the lighting with the remote control handset before replacing windows (lighting can operate independent of main fire being on or off).
4. Reinstall windows and barrier screens following steps in section "Window Re-Installation" on pages 52 - 53.

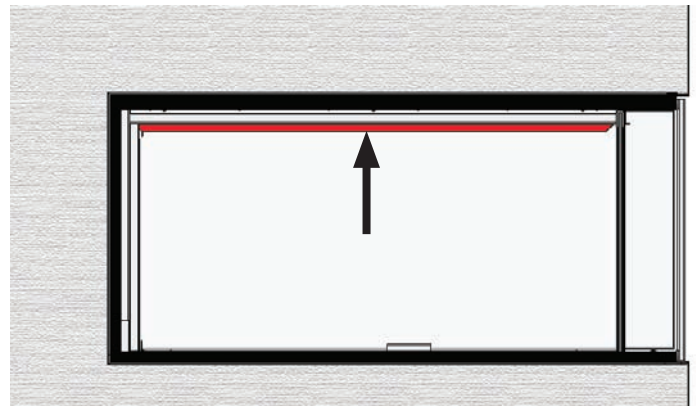

Lighting rail on both sides, just behind window

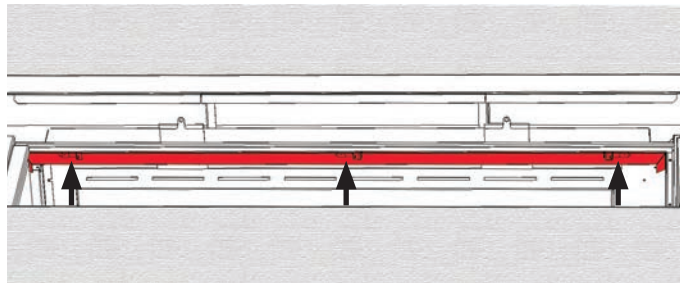

Position of 3 light bulbs looking up in the firebox

# Installation

To refit the window:

1. Remove any fuel bed media particle from the window bottom rail before installing the window.
2. Ensure the gasket is well fitted to the bottom of the window pane.

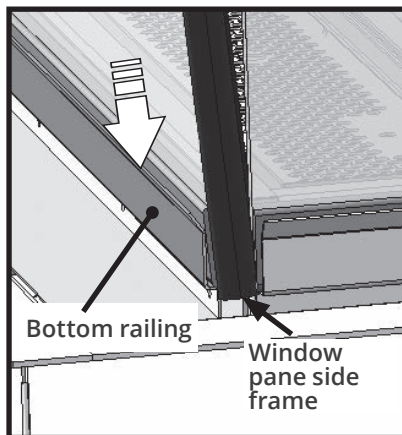
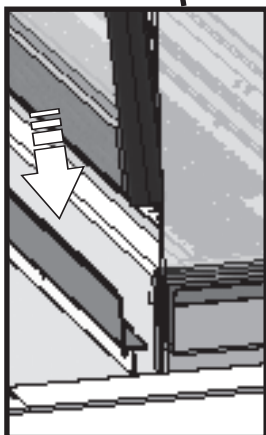
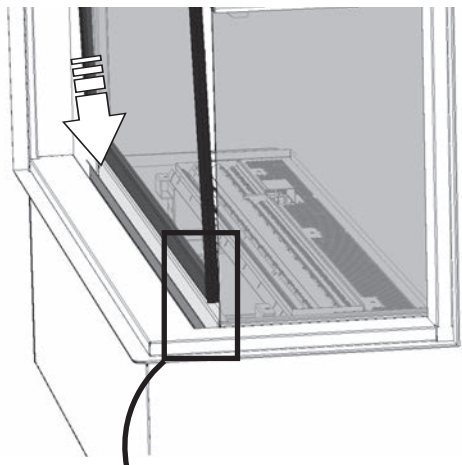
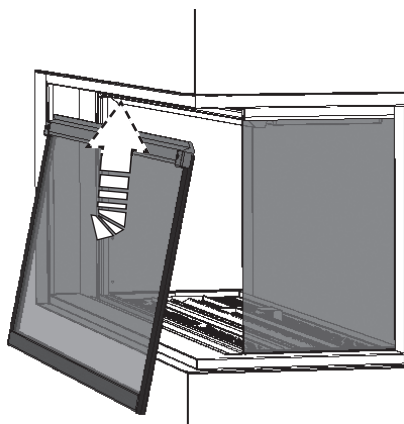

## Window Re-Installation

3. Insert the window behind the appliance's front panel and lower it into its bottom rail.
4. Push the top of the window pane against the fire-box. Ensure it is centered on the firebox so it seals properly.
5. While you hold it, pull down and hook one of the spring-loaded levers onto the window top black frame using the door handle. Repeat with the other lever.

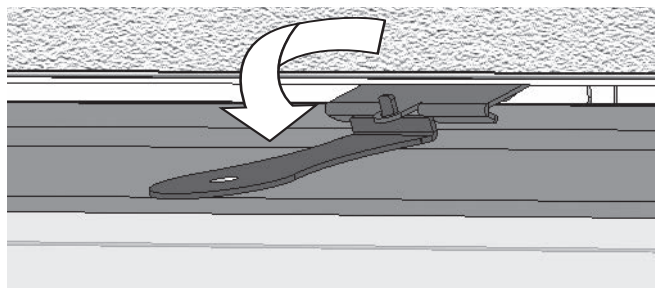

# Installation

6. Apply firm hand pressure around the window pane particularly on the top and sides to ensure the window is sealed tight against the firebox.

ENSURE THE FRONT WINDOW'S SILICONE GASKETS ARE WELL SEALED, FROM TOP TO BOTTOM, TO THE SIDE WINDOWS!

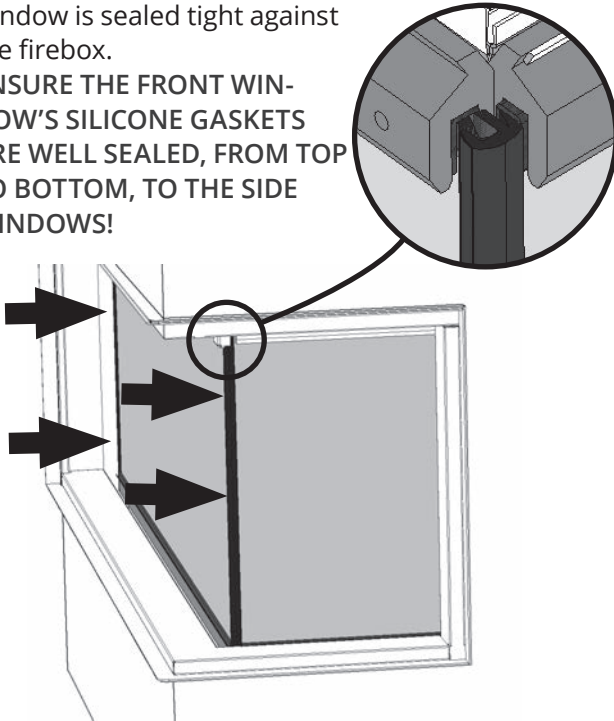

7. If the Hot Glass Warning plate has been removed from the front lower corner of the window, re-install it by sliding it between the glass and the frame as indicated.



**! WARNING: EXTREMELY HOT GLASS AND FIREPLACE**  
Risk of severe burns. Keep Children away from fireplace & controls.  
Risque de brûlures graves. Tenir les enfants à l'écart du foyer et des commandes.  
**AVERTISSEMENT : VITRE ET POYER EXTREMEMENT CHAUDS**

**! WARNING: EXTREMELY HOT GLASS AND FIREPLACE**  
Risk of severe burns. Keep Children away from fireplace & controls.

Hot Glass Warning Plate

# Window Re-Installation

## **WARNING**

The window units must be correctly installed, fastened and sealed after servicing or serious bodily injury and/or damage to the fireplace may result.

To ensure safe operation:

- Double-check that the bottom of each window frame is correctly installed in the bottom support railing;
- Verify that the retainer hooks are hooked properly to the top angle brackets;
- Pull out the top of each side window and release it to ensure the springs return it;
- Ensure the window is sealed before operation.

## **WARNING**

Failure to install the window correctly can:

- cause carbon monoxide to leak.
- affect the performance of the fireplace.
- damage components.
- cause overheating resulting in dangerous conditions.

Damage caused by incorrect window installation is not covered by the Valor Warranty.

# Installation

## Pair Remote Control Receiver to Handset

The receiver and the handset of the remote control system must be initially synchronized before the first use. The receiver is located on the bottom of the fireplace behind the front panel under the valve heat shield. The battery holder is located next to the wall switch.

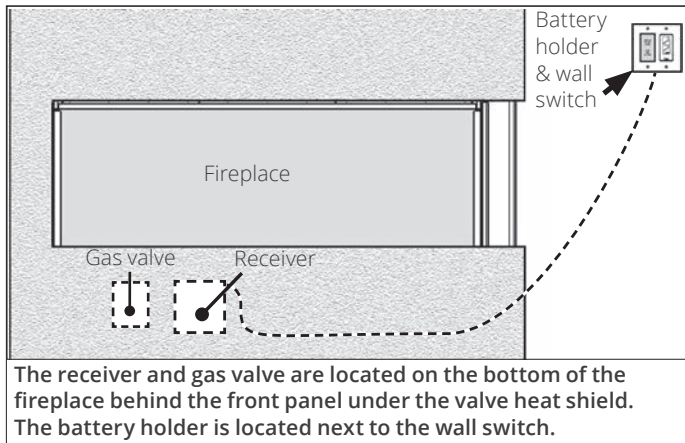

1. Insert two 1.5 V AAA alkaline batteries in the handset.
2. Behind the front panel of the appliance, slide the valve heat shield to the right and locate the receiver. Detach it from the Velcro and pull it out.

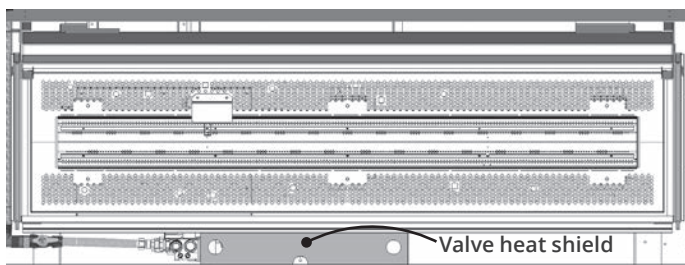



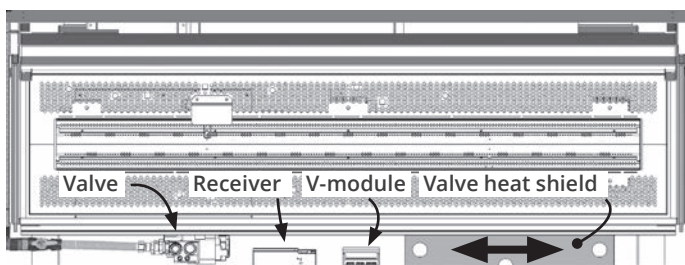

Top view—Valve heat shield closed

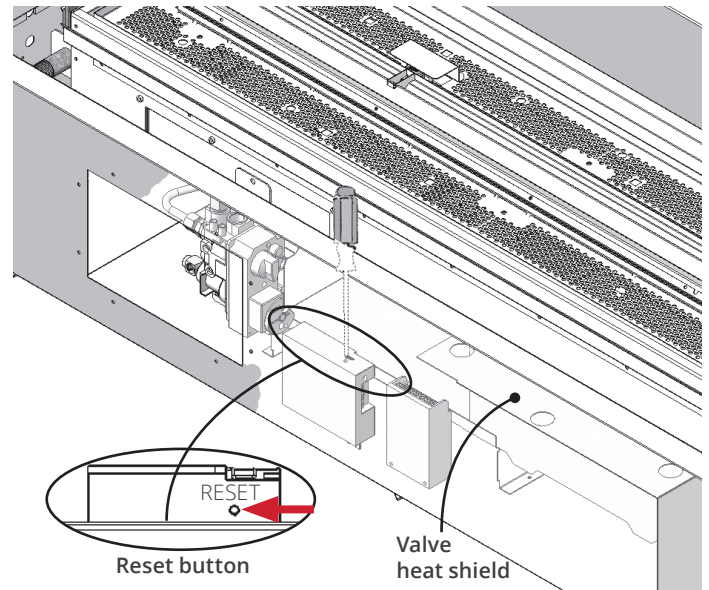

Top view—Slide valve heat shield opened

## Remote Control Set-Up



3. Locate the Reset button on the top side of the receiver.
4. With a thin object, press and hold the receiver's RESET button until you hear one short and one long beeps. After the second beep, release the reset button.
5. Within the subsequent 20 seconds, press and hold the  button on the remote handset for 2-3 seconds.  will be displayed on the handset during the pairing sequence. You will hear two short beeps confirming the pairing is done.  This is a one time pairing only and is not required when changing the batteries of the handset or battery holder. The remote control system is now ready to use.
6. If you hear one long beep, the pairing sequence has failed or the wiring is incorrect.
7. Put the valve heat shield back in place, over the valve, receiver and v-module.

### **WARNING**

**ALWAYS PUT THE VALVE HEAT SHIELD BACK IN PLACE over the valve, receiver and v-module! Otherwise, the controls can overheat and the fireplace stop working.**

# Installation

## Remote Control Set-Up

### Install Remote Control Handset Wall Holder

The remote control kit for this fireplace comes complete with a wall-mounted holder. This holder is not required in all installations but is provided as an optional feature for those customers who wish to mount the remote handset to the wall.

To install the holder to the wall, find a convenient



location and use the hardware provided with the kit. Cover the screws with the included caps to finish the mounting.

Once mounted, the holder is magnetic - simply place the remote gently into the holder.

**IMPORTANT:** The location of the remote control handset is important to assure proper temperature regulation. To obtain a constant temperature, we recommend that the handset should be **between 3 and 15 feet away from the appliance but not directly above it.** We also advise that the handset should be located away from any other heat source and not in direct sunlight as this may affect the temperature sensor located in the remote handset.

# Installation

## Check Operation

Turn the fireplace flame up and down using the remote control to confirm that the full range of inputs is achieved—see the remote control operation instructions in Appendix.

## Set Aeration (if necessary)

Light the fire and allow the unit to warm up for 10–15 minutes to evaluate the flame picture. The burner is equipped with an adjustable shutter to control primary aeration. The shutter is factory-set to an aeration gap which will give optimum performance for the vast majority of installations.

Depending of fuel bed used, altitude and other considerations, the flame picture may be improved by adjusting the aeration. The need for adjustment should be determined only by operating the appliance with the fuel bed, liners and window installed and evaluating the flame picture after a 15-minute warm-up.

**Increasing aeration** will cause the flames to appear more transparent and blue showing more ceramic effects glow.

**Decreasing aeration** will cause the flames to appear more yellow or orange showing less ceramic effects glow.

***Too little aeration may result in black carbon forming and dropping into the firebox.***

# Check Operation

To access the air shutter, remove the barrier screen and the base plate. The air shutter lever is located in front of the firebox behind the appliance front panel. Adjust the shutter by using a screwdriver as a lever to slide the shutter left or right.

## Air Shutter

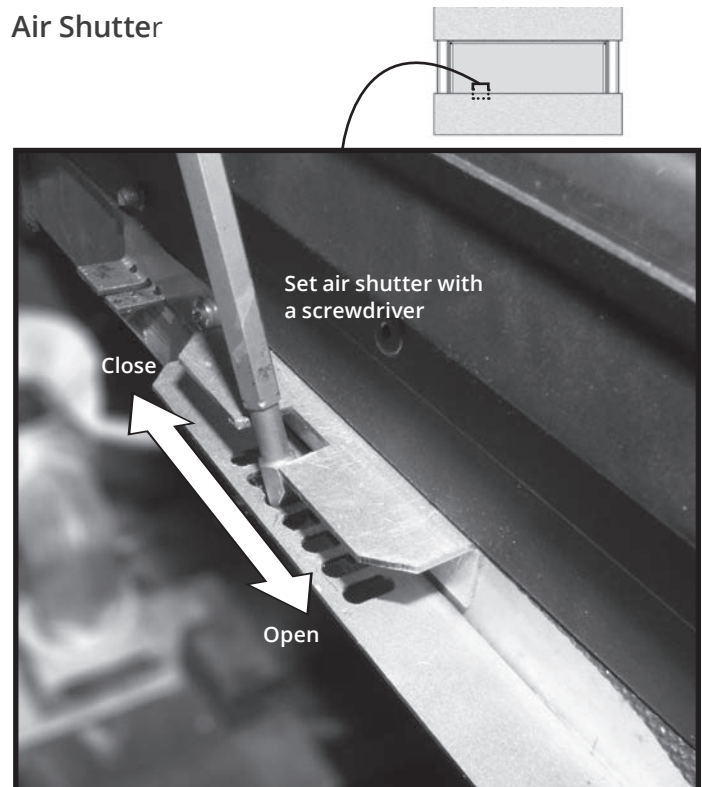



# Installation

## Reinstall Window Sill

1. Place the window sill on the fireplace's flange with the magnets behind the fireplace's front panel.

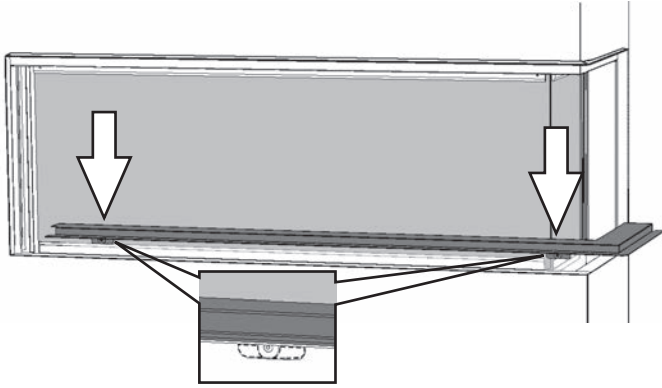

2. Push the sill down ensuring that the magnets underneath slide behind the fireplace's front panel.

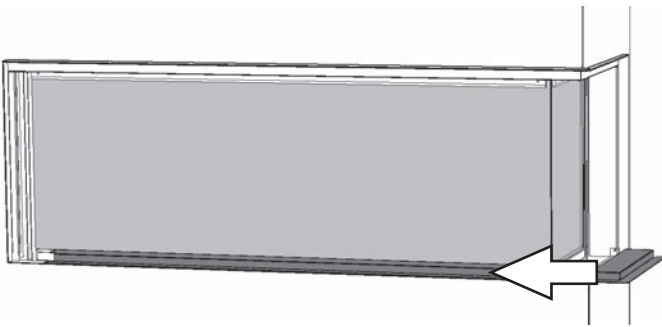

3. Pull the sill forward so it is flush with the fireplace's front flange.

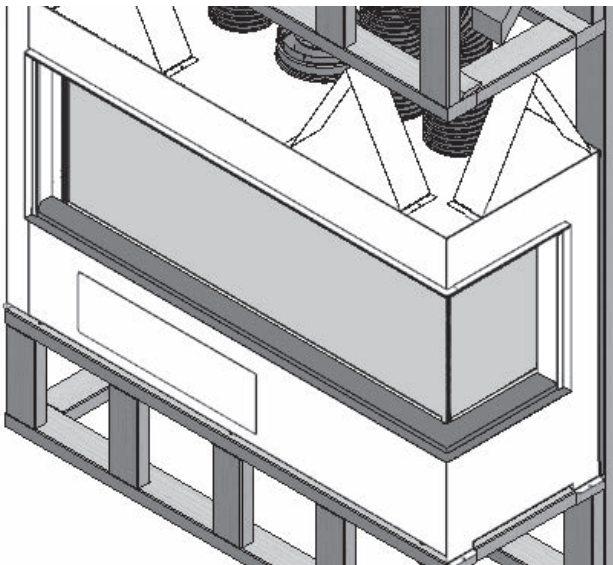

## Barrier Screen & Window Sill

### Install Barrier Screen

#### **WARNING**

**For safety purposes, make sure the barrier screen is installed on the fireplace after maintenance.**

1. Place the side screen on the window sill of the appliance opening, magnets inboard against plate flange. Push top against top plate flange.
2. Place the front screen, magnets inboard, against the ridge of the window sill; push the top of the screen against the ridge of the top plate. The front screen frame overlaps the side screen.
3. Ensure that the screens are secure.

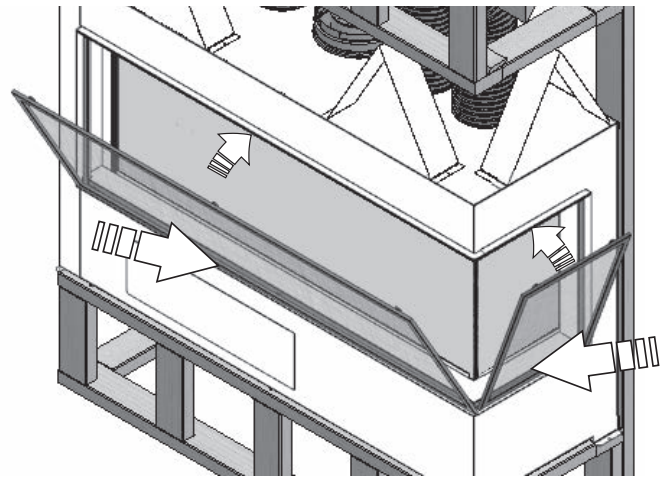

# Wiring Diagram

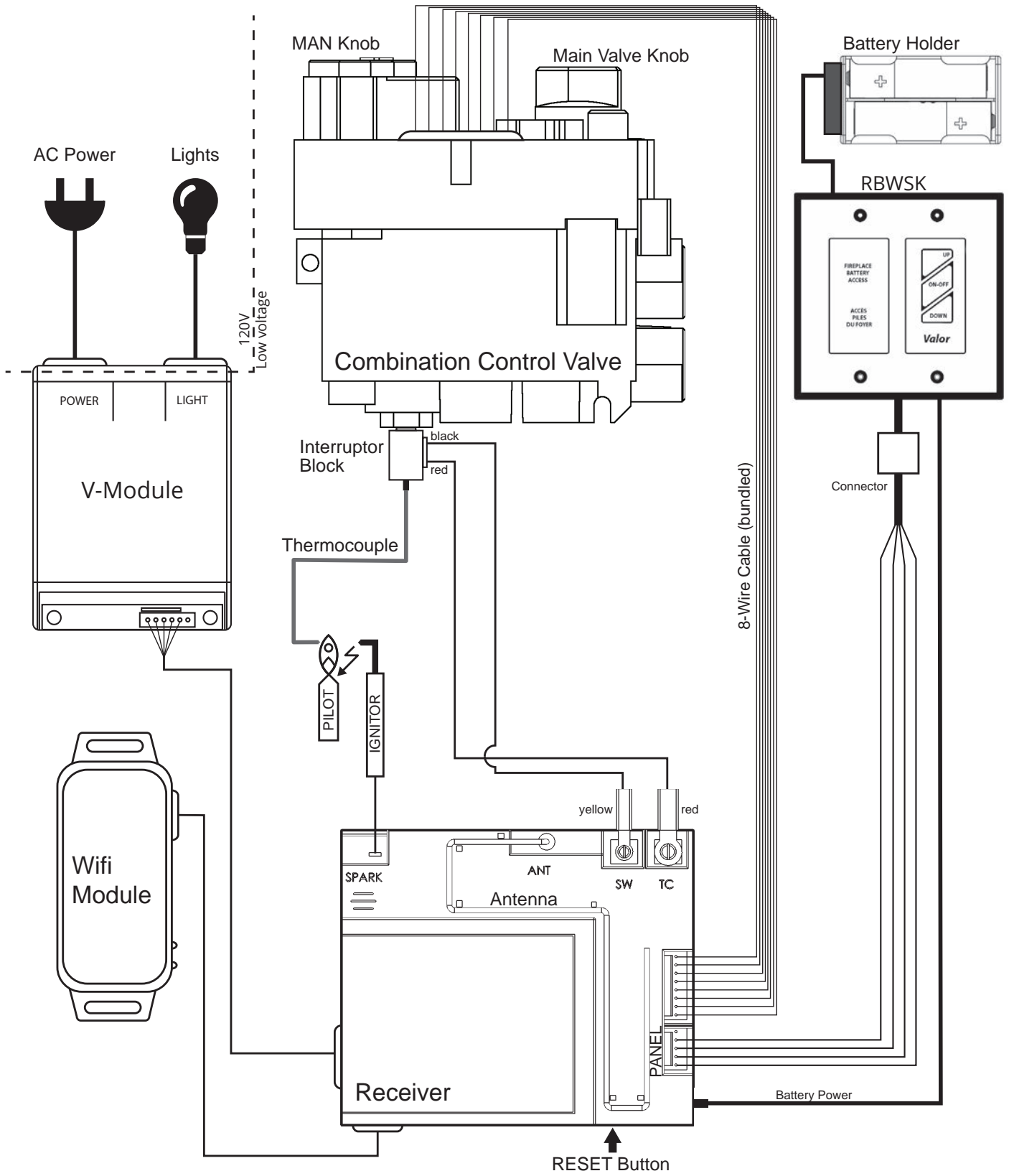

# Approved Venting Components

Approved Direct Vent Suppliers - Valor Models 2200											
 Venting Parts Description		Venting Parts Code / availability by Manufacturer								BDM	
		DURA-VENT 4 x 6-5/8"	DURA-VENT 5 x 8"	SELKIRK	ICC EXCEL DIRECT	SECURE VENT	RLH INDUSTRIES	AMERIVENT	MILES INDUSTRIES		
Termination Caps	Horizontal	Standard Co-axial	46DVA-HC	58DVA-HC	4DT-HC	TM-4HT	—	—	—	658DVK2	940160
		Deluxe Co-axial	—	—	—	TM-RHT	—	—	4DHCS square	—	940160
		High Wind Co-axial	—	—	—	—	SV4CHC	—	—	—	—
	Vertical	Standard Co-axial	46DVA-VC	58DVA-VC	4DT-VT	—	—	HSDV4658-1313	4DVC	—	940264
			4DH-1313	—	940364						
			—	—	940206LP						
		High Wind Co-axial	46DVA-VCH	58DVA-VCH	—	TM4-SVT	SV4CGV	—	—	—	—
Extended Co-axial	46DVA-VCE	58DVA-VCE	—	—	—	—	—	—	—		
Snorkel, 14" Rise	—	—	4DT-ST14	TM-4ST14	—	—	4D14S	—	94040614		
Snorkel, 36" Rise	—	—	4DT-ST36	TM-4ST36	—	—	4D36S	—	94040636		
Adjustable Pipe Length and Pipe Extensions 4" x 6-5/8"	Galvanized or Black	46DVA-08A 46DVA-08AB (3" to 7")	—	4DT-ADJ 4DT-ADJ(B)	—	—	—	4D7A or 4D7AB (3" to 5")	—	94610608 (4" to 8-1/2")	
		46DVA-16A 46DVA-16AB (3" to 14-1/2")	—	—	TC-4DLS1 TC-4DLS1B	SV4LA SV4LBA	—	4D12A or 4D12AB (3" to 10")	—	94610616 (4" to 16")	
	Galvanized or Black	46DVA-17TA 46DVA-17TAB (11" to 17")	—	—	TC-4DLS2 TC-4DLS2B (1-7/8" - 21")	SV4LA12 SV4LBA12	—	4D16A or 4D16AB (3" to 14")	—	—	
	Galvanized or Black	46DVA-24TA 46DVA-24TAB (17" to 24")	—	—	TC-4DLA30 TC-4DLA30B (16.5"-29")	SV4LA24 SV4LBA24	—	4D26A or 4D26AB (3" to 24")	—	—	
	Coaxial Flex	46DVA-48FF 46DVA-120FF	—	—	—	—	—	—	—	—	
DV 45° Elbows	Galvanized	46DVA-E45	58DVA-E45	—	TE-4DE45	—	—	4D45L	—	94620645	
	Black	46DVA-E45B	58DVA-E45B	—	TE-4DE45B	SV4EBR45	—	4D45LB	—	94620645B	
	Galvanized Swivel	—	—	4DT-EL45	—	SV4E45	—	—	—	—	
	Black Swivel	—	—	4DT-EL45(B)	—	SV4EB45	—	—	—	—	
DV 90° Elbows	Galvanized	46DVA-E90	58DVA-E90	—	TE-4DE90	—	—	4D90L	—	—	
	Black	46DAV-E90B	58DAV-E90B	—	TE-4DE90B	SV4EBR90	—	4D90LB	—	—	
	Galvanized Swivel	—	—	4DT-EL90	—	SV4E90	—	—	—	94620690	
	Black Swivel	—	—	4DT-EL90(B)	—	SV4EB90	—	—	—	94620690B	

# Approved Venting Components

Venting Parts Description			Venting Parts Code / availability by Manufacturer								
			DURA-VENT 4 x 6-5/8"	DURA-VENT 5 x 8"	SELKIRK	ICC EXCEL DIRECT	SECURE VENT	RLH INDUSTRIES	AMERIVENT	MILES INDUSTRIES	BDM
Pipes	6" long	Galvanized	46DVA-06	58DVA-06	4DT-06	TC-4DL6	SV4L6	—	—	—	94610606
		Black	46DVA-06B	58DVA-06B	4DT-06(B)	TC-4DL6B	SV4LB6	—	—	—	90410606B
	7" long	Galvanized	—	—	—	—	—	—	4D7	—	—
		Black	—	—	—	—	—	—	4D7B	—	—
	9" long	Galvanized	46DVA-09	58DVA-09	4DT-09	TC-4DL9	—	—	—	—	94610609
		Black	46DVA-09B	58DVA-09B	4DT-09(B)	TC-4DL9B	—	—	—	—	94610609B
	12" long	Galvanized	46DVA-12	58DVA-12	4DT-12	TC-4DL1	SV4L12	—	4D12	—	94610612
		Black	46DVA-12B	58DVA-12B	4DT-12(B)	TC-4DL1B	SV4LB12	—	4D12B	—	94610612B
	18" long	Galvanized	46DVA-18	58DVA-18	4DT-18	—	—	—	—	—	94610618
		Black	46DVA-18B	58DVA-18B	4DT-18(B)	—	—	—	—	—	94610618B
	24" long	Galvanized	46DVA-24	58DVA-24	4DT-24	TC-4DL2	SV4L24	—	4D2	—	94610624
		Black	46DVA-24B	58DVA-24B	4DT-24(B)	TC-4DL2B	SV4LB24	—	4D2B	—	94610624B
	36" long	Galvanized	46DVA-36	58DVA-36	4DT-36	TC-4DL3	SV4L36	—	4D3	—	94610636
		Black	46DVA-36B	58DVA-36B	4DT-36(B)	TC-4DL3B	SV4LB36	—	4D3B	—	94610636B
	48" long	Galvanized	46DVA-48	58DVA-48	4DT-48	TC-4DL4	SV4L48	—	4D4	—	94610648
		Black	46DVA-48B	58DVA-48B	4DT-48(B)	TC-4DL4B	SV4LB48	—	4D4B	—	94610648B
Flashings	Roof Flashing 0/12-6/12		46DVA-F6	58DVA-F6	4DT-AF6	TF-4FA	SV4FA	—	4DF (0/12-5/12)	—	949606012
	Roof Flashing 7/12-12/12		46DVA-F12	58DVA-F12	4DT-AF12	TF-4FB	SV4B	—	4DF12 (6/12-12/12)	—	949606712
	Flat Roof Flashing		46DVA-FF	58DVA-FF	—	TF-4F	SV4F	—	—	—	949606001
	Masonry Flashing		—	—	—	TF-4MF	—	—	—	—	—
	New Siding Flashing		—	—	—	—	—	—	—	658NSFK	—
Various Venting System Parts	Wall Thimble		46DVA-WT	58DVA-WT	4DT-WT	TM-4WT	SV4RSM	—	4DWT	—	949064U
	Storm Collar		46DVA-SC	58DVA-SC	4DT-SC	TM-SC	SV4AC	—	4DSC	—	94960608
	Decorative Plate		46DVA-DC	58DVA-DC	4DT-CS	TM-4TR TM-4TP	SV4PF	—	4DFPB	—	94940612
	Cathedral Ceiling Support		46DVA-CS	58DVA-CS	4DT-CCS	TM-4SS	—	—	4DRSB	—	949506KT
	Ceiling Firestop / Floor Support		46DVA-FS	58DVA-FS	4DT-FS	TM-4TDS TM-CS	SV4BF SV4SD	—	4DFSP	—	94980612
	Attic Radiation Shield / Firestop		—	—	—	TM-4AS	—	—	4DAIS12 (12") 4DAIS36 (36")	—	94930620A
	Wall Strap		46DVA-WS	58DVA-WS	4DTWS	TM-WS	—	—	4DWS	—	949164
	Vinyl Siding Standoff		46DVA-VSS	58DVA-VSS	4DT-VS	TM-VSS	SV4VS	—	4DHVS	—	94800615S
	Elbow Strap / Offset Support		46DVA-ES	58DVA-ES	4DT-OS	TM-OS	—	—	—	—	949264
	Terminal Guard		46DVA-WG	58DVA-WG	—	TM-HTS TM-RHTS	—	—	—	845TG 658TG	940164SHRD

- Notes:**
1. Follow instructions supplied with each manufacturer's components.
  2. Unless otherwise specified, all the parts and assemblies from the above table are to be used with 4" x 6-5/8" pipes.
  3. Do not mix components from different vent manufacturers.
  4. Termination caps manufactured by RLH Industries or American Metal Products are from Homestyle Chimney Collection and can be ordered in one of the following finishes: a) aluminium; b) black powder coated; c) solid copper.

# Commonwealth of Massachusetts

## State of Massachusetts Carbon Monoxide Detector/Vent Terminal Signage Requirements

For all side wall horizontally vented gas fueled equipment installed in every dwelling, building or structure used in whole or in part for residential purposes, including those owned or operated by the Commonwealth and where the side wall exhaust vent termination is less than seven (7) feet above finished grade in the area of the venting, including but not limited to decks and porches, the following requirements shall be satisfied:

### 1. INSTALLATION OF CARBON MONOXIDE DETECTORS.

At the time of installation of the side wall horizontal vented gas fueled equipment, the installing plumber or gas fitter shall observe that a hard wired carbon monoxide detector with an alarm and battery back-up is installed on the floor level where the gas equipment is to be installed. In addition, the installing plumber or gas fitter shall observe that a battery operated or hard wired carbon monoxide detector with an alarm is installed on each additional level of the dwelling, building or structure served by the side wall horizontal vented gas fueled equipment. It shall be the responsibility of the property owner to secure the services of qualified licensed professionals for the installation of hard wired carbon monoxide detectors.

a. In the event that the side wall horizontally vented gas fueled equipment is installed in a crawl space or an attic, the hard wired carbon monoxide detector with alarm and battery back-up may be installed on the next adjacent floor level.

b. In the event that the requirements of this subdivision can not be met at the time of completion of installation, the owner shall have a period of thirty (30) days to comply with the above requirements; provided, however, that during said thirty (30) day period, a battery operated carbon monoxide detector with an alarm shall be installed.

2. APPROVED CARBON MONOXIDE DETECTORS. Each carbon monoxide detector as required in accordance with the above provisions shall comply with NFPA 720 and be ANSI/UL 2034 listed and IAS certified.

3. SIGNAGE. A metal or plastic identification plate shall be permanently mounted to the exterior of the building at a minimum height of eight (8) feet above grade directly in line with the exhaust vent terminal for the horizontally vented gas fueled heating appliance or equipment. The sign shall read, in print size no less than one-half (1/2) inch in size, "GAS VENT DIRECTLY BELOW. KEEP CLEAR OF ALL OBSTRUCTIONS".

4. INSPECTION. The state or local gas inspector of the side wall horizontally vented gas fueled equipment shall not approve the installation unless, upon inspection, the inspector observes carbon monoxide detectors and signage installed in accordance with the provisions of 248 CMR 5.08(2)(a)1 through 4.

(b) EXEMPTIONS: The following equipment is exempt from 248 CMR 5.08(2)(a)1 through 4:

1. The equipment listed in Chapter 10 entitled "Equipment Not Required To Be Vented" in the most current edition of NFPA 54 as adopted by the Board; and

2. Product Approved side wall horizontally vented gas fueled equipment installed in a room or structure separate from the dwelling, building or structure used in whole or in part for residential purposes.

# Commonwealth of Massachusetts

(c) MANUFACTURER REQUIREMENTS - GAS EQUIPMENT VENTING SYSTEM PROVIDED. When the manufacturer of Product Approved side wall horizontally vented gas equipment provides a venting system design or venting system components with the equipment, the instructions provided by the manufacturer for installation of the equipment and the venting system shall include:

1. Detailed instructions for the installation of the venting system design or the venting system components; and
2. A complete parts list for the venting system design or venting system.

(d) MANUFACTURER REQUIREMENTS - GAS EQUIPMENT VENTING SYSTEM NOT PROVIDED. When the manufacturer of a Product Approved side wall horizontally vented gas fueled equipment does not provide the parts for venting the flue gases, but identifies "special venting systems", the following requirements shall be satisfied by the manufacturer:

1. The referenced "special venting system" instructions shall be included with the appliance or equipment installation instructions; and
2. The "special venting systems" shall be Product Approved by the Board, and the instructions for that system shall include a parts list and detailed installation instructions.

(e) A copy of all installation instructions for all Product Approved side wall horizontally vented gas fueled equipment, all venting instructions, all parts lists for venting instructions, and/or all venting design instructions shall remain with the appliance or equipment at the completion of the installation.

# Appendix A - Lighting Instructions Plate

## FOR YOUR SAFETY, READ BEFORE LIGHTING

**WARNING: If you do not follow these instructions exactly, a fire or explosion may result causing property damage, personal injury or loss of life.**

- A. This appliance has a pilot which must be lighted by hand, remote control, or wall switch. Follow these instructions exactly. To save gas, turn the pilot off when not using the appliance for a prolonged period of time.
- B. **BEFORE LIGHTING**, smell all around the appliance area for gas. Be sure to smell next to the floor because some gases are heavier than air and will settle on the floor.

### WHAT TO DO IF YOU SMELL GAS

- Do not try to light any appliance.
  - Do not touch any electric switch; do not use any phone in your building.
  - Immediately call your gas supplier from a neighbor's phone. Follow the gas supplier's instructions.
  - If you cannot reach your gas supplier, call the fire department.
- C. Use only your hand to push in or turn the control knobs. Never use tools. If the knobs will not push in or turn by hand, don't try to repair them; call a qualified service technician. Force or attempted repair may result in a fire or explosion.
- D. Do not use this appliance if any part has been under water. Immediately call a qualified service technician to inspect the appliance and to replace any part of the control system and any gas control, which has been under water.

## LIGHTING INSTRUCTIONS

1. **STOP!** Read the safety information above.
2. **TO CLEAR ANY GAS, turn main valve off by pressing OFF (red dot) button on remote handset (1).**

- Wait five (5) minutes to clear out any gas, then smell for gas, including near the floor. **If you smell gas, STOP!** Follow "B" in the safety information above on this label. If you don't smell gas, go to the next step.

3. **AUTOMATIC IGNITION:** MAN-knob (2) in ON position. Ensure Flame Adjustment knob (3) is set to lowest setting (U) (Fig. 1). Locate the pilot (Fig. 3.) inside of firebox at left hand side.

- On the remote control handset, press the OFF button (red dot) and large flame button (🔥) simultaneously; a short acoustic signal confirms the start has begun.
- Further short acoustic signals indicate the ignition process is in progress.
- When the pilot is lit, the Flame Adjustment knob (3) will automatically rotate to the highest setting.
- Press the small flame button (🔥) on the remote control handset to reduce the flame height.

4. **MANUAL IGNITION:** MAN-knob (2) in MAN position (Fig. 2). With the window off, locate the pilot (Fig. 3) inside of firebox at left hand side.

- Set Flame Adjustment knob (3) to the lowest setting (U).
- Push down the metallic core (4) with a pen or similar instrument; this will establish the pilot gas flow.
- Light gas at the pilot (5) with a match.
- Continue holding down metal core (4) for about 10 seconds; after release, pilot should remain lit.
  - If the pilot will not stay lit after several tries, turn the gas control knob (3) to OFF (U) and call your local service technician or gas supplier.
- Reinstall the window and set the MAN-knob (2) to ON; turn Flame Adjustment knob (3) up (↗) or down (↘) manually or use the flame buttons (🔥)(🔥) on the remote control handset to adjust the flame height.

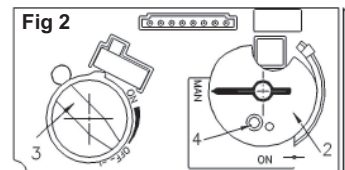
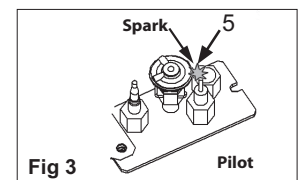
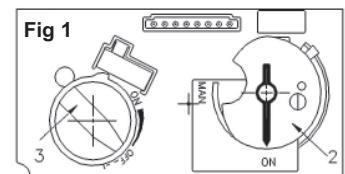

## TO TURN OFF GAS TO APPLIANCE

**AUTOMATIC SHUT-OFF** (using the remote control handset):

- Press and hold the small flame button (🔥) on the remote control handset to shut-off the main burner gas flow.
- Press OFF button (red dot) on remote handset to shut-off the appliance, including pilot flame.

# Appendix B - Remote Control Operation

## Initial Pairing

Before using the remote control system for the first time, the receiver and the handset must be paired. See "Remote Control Set-Up" on page 54

## Main Display

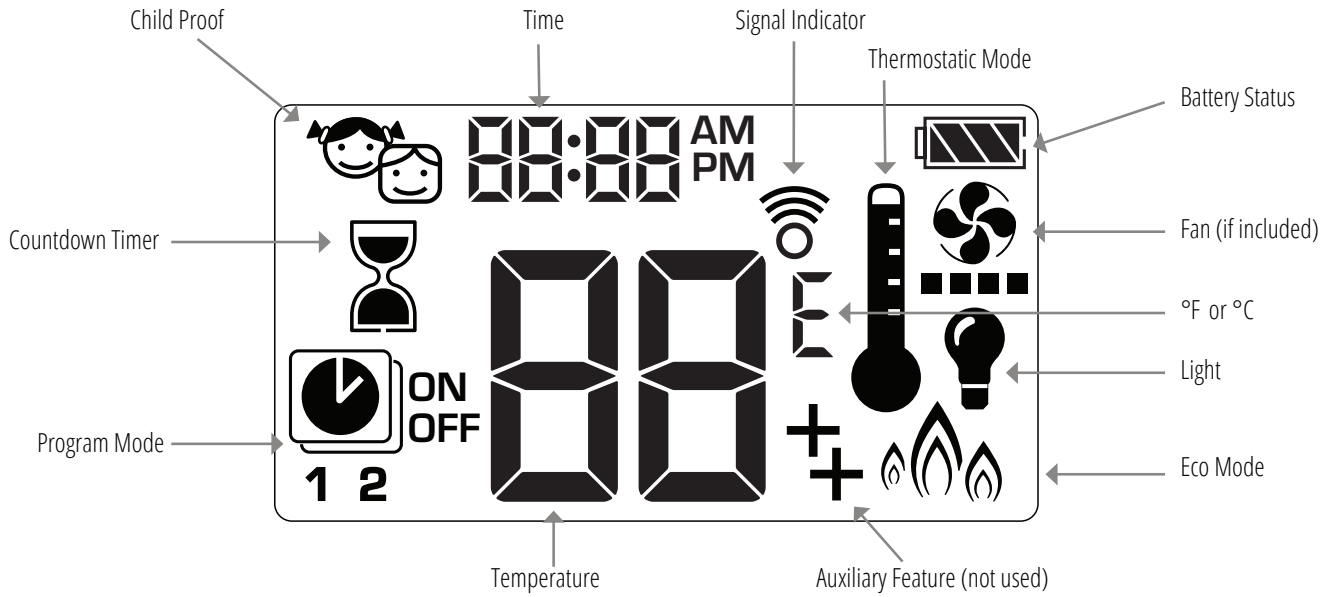

## To Turn On Fire

**NOTE:** When pilot ignition is confirmed, motor automatically turns to maximum flame height.

One-Button lighting (default):

Two-Button lighting: + simultaneously

Press and hold for 4 seconds, until 8 short beeps and a blinking series of lines confirms the start sequence has begun. Release button.

Main gas flows once pilot ignition is confirmed.

Handset automatically goes into manual mode after main burner ignition.

### Standby Mode (Pilot Flame)

Press and hold to set appliance to pilot flame.

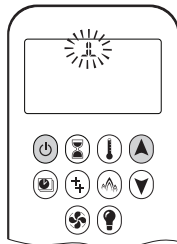
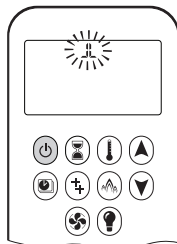

**CAUTION:** If the pilot does not stay lit after several tries call your local service technician or gas supplier.

## To Turn Off Fire

Press to turn OFF.

**Note:** There is a 2 minute delay after switching off before the next ignition is possible.

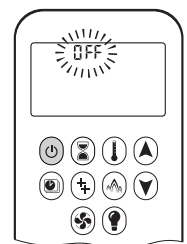

**CAUTION:** Always check the fire and pilot visually to ensure they are off.

## Flame Height Adjustment

To increase flame height, press and hold .

To decrease flame height, press and hold . You may hold the button down until the fire is set to pilot flame only.

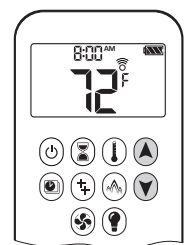





# Appendix B - Remote Control Operation

## Designated Low Fire and High Fire

To go to low fire, double-click , "LO" is displayed.

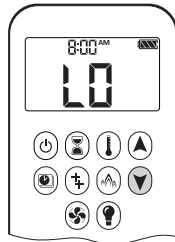
**Note:** Flame goes to high fire first before going to low fire.



To go to high fire, double-click , "HI" is displayed.

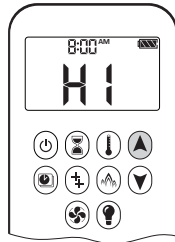

## Choosing 1-Button or 2-Button Ignition

On the remote control handset, you can choose a 1-button or 2-button ignition. You can also choose to activate or deactivate some of the functions. By default, the handset is set to a 1-button ignition.

To change from 1-button to 2-button ignition, remove the batteries, wait 10 seconds, reinsert batteries, and immediately when the display flashes, press and hold the  button for 10 seconds. **ON** is displayed and **1** is flashing. When change is complete, **1** changes to **2**.

To change from 2-button to 1-button ignition, proceed the same as above. **ON** is displayed and **2** is flashing. When change is complete, **2** changes to **1**.

## Deactivating or Activating Functions

These functions are active by default, but can be deactivated at any time:

- Child Proof
- Program Mode
- Thermostatic Mode
- Eco Mode
- Circulating Fan Operation
- Countdown Timer

## To deactivate functions:

1. Install batteries. All icons are displayed and flashing.
2. While the icons are flashing, press the relevant function button and hold for 10 seconds.
3. The function icon will flash until deactivation is complete. Deactivation is complete when the function icon and two horizontal bars () are displayed.

**Note:** If a deactivated button is pressed, there is no function, and the two horizontal bars are displayed.

## To activate functions:

1. Install batteries. All icons are displayed and flashing.
2. While the icons are flashing, press the relevant function button and hold for 10 seconds.
3. The function icon will continue to flash until activation is complete, and then turn solid. Activation is complete when the function icon is displayed.







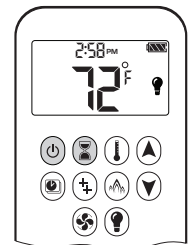







## Setting Celsius or Fahrenheit

To change between °C and °F, press and hold  +  simultaneously.

**Note :** °C = 24-hour clock  
°F = 12-hour clock



## Setting the Time

1. Press  +  simultaneously. **Day** flashes.
2. Press  +  to select a number to correspond with the day of the week.
  - 1 = Monday
  - 2 = Tuesday
  - 3 = Wednesday
  - 4 = Thursday
  - 5 = Friday
  - 6 = Saturday
  - 7 = Sunday
3. Press  +  simultaneously. **Hour** flashes.
4. To select hour press  or .
5. Press  +  simultaneously. **Minutes** flash.
6. To select minutes press  or .
7. To confirm, press  +  simultaneously or wait.

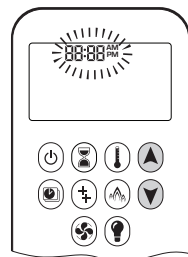

# Appendix B - Remote Control Operation

## Child Proof

Your handset can be set to lock out all commands to the fireplace, except OFF.

### To turn Child Proof ON:

1. Press and hold (⏻) + (⏮) simultaneously.
2. (👤) is displayed. Child Proof is now active.

### To turn Child Proof OFF:

1. Press and hold (⏻) + (⏮) simultaneously.
2. (👤) disappears. Child Proof is now inactive, and the handset has full function.

## Countdown Timer

You can set your fireplace to automatically turn off at the end of a timer.

### To set a Countdown Timer:

1. Press and hold (⌚) until (⌚) is displayed.  
**Hour** flashes.
2. Press (▲) or (▼) to select Hour.
3. To confirm, press (⌚).  
**Minutes** flash.
4. Press (▲) or (▼) to select Minutes.
5. To confirm, press (⌚) or wait.

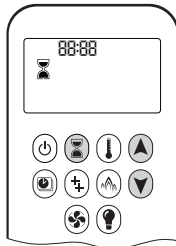

### To turn off a Countdown Timer:

1. Press (⌚), and the (⌚) countdown disappears.

**Note:** The Countdown Timer only works in Manual, Thermostatic, and Eco modes. Maximum countdown time is 9 hours and 50 minutes.

## Light/Dimmer Operation

### On:

Press (💡), (💡) is displayed. Light is on at preset level.

### Off:

Press (💡), (💡) disappears. Light turns off.

### Setting:

1. Press and hold (💡) until (💡) flashes.
2. To adjust light between 20-100% press (▲) or (▼).
3. To confirm setting either press (💡) or wait.  
(💡) is displayed.

**Note:** The light works independently of the pilot flame. If you want the light on but no flame, press (💡) button.

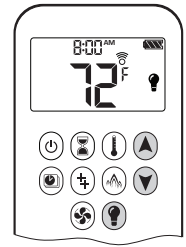

# Appendix B - Remote Control Operation

## Modes of Operation

### Thermostatic Mode

The room temperature is measured and compared to the set temperature. The flame height is automatically adjusted to achieve the set temperature.



### Program Mode

The temperature is controlled by Programs 1 and 2, each of which can be set to go on and off at specific times, at a set temperature.



### Eco Mode

Flame height modulates between high and low. If the room temperature is lower than the set temperature, the flame height stays on high for a longer period of time. If the room temperature is higher than the set temperature, the flame height stays on low for a longer period of time. One cycle lasts approximately 20 minutes.





 If any of the above modes (Thermostatic, Program, or Eco) are engaged by the MyFire app over WiFi, the handset will display **APP**.

### Manual Mode

The on/off status of the fireplace, as well as flame height, are manually controlled by the user.





## Thermostatic Mode

### On:

Press .  is displayed. Preset temperature displays briefly, followed by the room temperature.







### Setting Desired Temperature:

1. Press and hold  until  is displayed and set temperature flashes.
2. To adjust set temperature, press  or .
3. To confirm, press  or wait.



### Off:

1. Press .
2. Press  or  to go to Manual Mode.
3. Press  to go to Program Mode.
4. Press  to go to Eco Mode.





## Program Mode

### On:

Press .  1 or 2, **ON** or **OFF** are displayed.



### Off:

1. Press , , or  to go to Manual Mode.
2. Press  to go to Thermostatic Mode.
3. Press  to go to Eco Mode.

**Note:** The set temperature for Thermostatic Mode is the temperature for the ON time in Program Mode. Changing the Thermostatic Mode set temperature also changes the ON time temperature in Program Mode.

### Default Settings:

- ON TIME (Thermostatic) TEMPERATURE: 70°F / 21°C
- OFF TIME TEMPERATURE: "— —" (pilot flame only)

# Appendix B - Remote Control Operation

## Temperature Setting:

1. Press and hold until flashes. **ON** and set temperature (set in Thermostatic Mode) is displayed.
2. To continue, press or wait. **OFF** displayed, temperature flashes.
3. Select off temperature by pressing or .
4. To confirm, press .

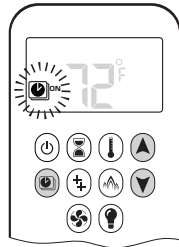

**Note:** The on (Thermostatic) and off set temperatures are the same for each day.

## Day Setting:

1. **ALL** flashes. Press or to choose between:
  - **ALL** = same settings ON-OFF every day
  - **SA:SU** = same settings ON-OFF Saturday and Sunday
  - **1, 2, 3, 4, 5, 6, 7** = daily timer—unique ON-OFF settings for a single day of the week, for multiple days of the week or for every day of the week.
2. To confirm, press .

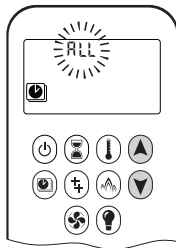

## ALL Selected

### On Time Setting (PROGRAM 1)

1. **1, ON** are displayed. **ALL** is displayed briefly. Hour flashes.
2. To select hour, press or .
3. To confirm, press . **1, ON** are displayed. **ALL** displayed briefly. Minutes flash.
4. To select minutes, press or .
5. To confirm, press .

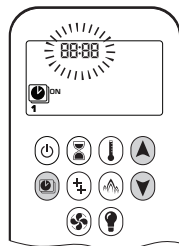

## Off Time Setting (PROGRAM 1)

1. **1, OFF** are displayed. **ALL** is displayed briefly. Hour flashes.
2. To select hour, press or .
3. To confirm, press . **1, OFF** are displayed. **ALL** displayed briefly. Minutes flash.
4. To select minutes, press or .
5. To confirm, press .

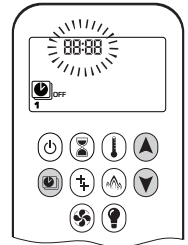

**Note:** Either continue to PROGRAM 2 and set ON and OFF times or stop programming at this point, and PROGRAM 2 remains deactivated.

**Note:** PROGRAM 1 and 2 use the same ON (Thermostatic) and OFF temperatures. Once a new ON (Thermostatic) and/or OFF temperature has been set, that temperature becomes the new default setting.

**Note:** ON and OFF times programmed for PROGRAM 1 and PROGRAM 2 become the new default times.

The batteries must be removed to clear the PROGRAM 1 and PROGRAM 2 ON and OFF times and temperatures.

## SA:SU or Daily Timer (1-7) Selected

- Set on time and off time using the same procedure as "ALL Selected" above.
- Waiting to finish setting.

## Eco Mode

### On:

Press button to enter Eco Mode. is displayed.

Flame height modulates between high and low every 20 minutes.

### Off:

Press button to exit Eco Mode. disappears.



# Appendix B - Remote Control Operation

## Low Battery Indication

**⚠ CAUTION:** Do not use a screwdriver or other metallic object to remove the batteries from the battery holder or the handset. This could cause a short circuit.

### Handset

The battery icon  will show when the battery needs to be replaced. Replace with two 1.5 V AAA alkaline batteries.

### Receiver

Frequent beeps for 3 seconds when the motor turns indicate the batteries in the battery holder need to be replaced. Replace with four 1.5 V AA alkaline batteries.

## Automatic Shut Off

### Countdown Timer

At the end of countdown time period, the fire turns off. The Countdown Timer only works in Manual, Thermostatic, and Eco Modes. Maximum countdown time is 9 hours and 50 minutes.

### Low Battery Receiver

With low battery power in the battery holder, the system shuts off the fire completely. (This will not happen if the power is completely interrupted.)

### Seven Day Shut Off

The system shuts off the fire completely if there is no change in flame height for 7 days.

### Automatic Turn Down

#### 3 Hour No Communication Function

The valve will turn to pilot flame if there is no communication between the handset and receiver for a 3-hour period. The fire will continue to function normally when communication is restored.

### Radio Frequency

918.0 MHz for USA and Canada.

This device complies with Part 15 of the FCC Rules and with Industry Canada license-exempt RSS standard(s). Operation is subject to the following two conditions:

- (1) this device may not cause harmful interference, and
- (2) this device must accept any interference received, including interference that may cause undesired operation.

# Appendix B - Remote Control Operation

## Error Codes

In the event of an error condition with the handset or fireplace, the handset will display an error code.

Failure Code	Message on Handset	Duration of Display	Symptom	Possible Cause
F04	F04	4 sec	<ul style="list-style-type: none"> <li>No pilot flame within 30 sec</li> <li><b>Note:</b> after 3 failed ignition sequences, F06 shown</li> </ul>	<ul style="list-style-type: none"> <li>No gas supply</li> <li>Air in pilot supply line</li> <li>No spark</li> <li>Reversed polarity in thermocouple wiring</li> </ul>
F06	F06	4 sec	<ul style="list-style-type: none"> <li>3 failed ignition sequences in 5 minutes</li> <li>Fire is not responding, no pilot flame</li> </ul>	<ul style="list-style-type: none"> <li>No gas supply</li> <li>Air in pilot supply line</li> <li>No spark</li> <li>Reversed polarity in thermocouple wiring</li> <li>Incorrect pilot orifice if valve has been converted from LPG to NG or vice versa</li> </ul>
F07	Low battery symbol 	Permanent	<ul style="list-style-type: none"> <li>Battery icon flashes on handset display</li> </ul>	<ul style="list-style-type: none"> <li>Low battery in handset</li> </ul>
F09	F09	4 sec	<ul style="list-style-type: none"> <li>Fire is not responding</li> <li>No electronic control of fire</li> </ul>	<ul style="list-style-type: none"> <li>Down arrow button (▼) was not pressed during pairing</li> <li>Receiver and handset are not synced</li> </ul>
F46	F46	4 sec	<ul style="list-style-type: none"> <li>Fire is not responding</li> <li>Intermittent response</li> <li>No electronic control of fire</li> </ul>	<ul style="list-style-type: none"> <li>No or bad connection between receiver and handset</li> <li>No power at receiver (batteries low)</li> <li>Low communication range (mains adapter faulty, handset not communicating with receiver)</li> </ul>

# Appendix C - Wall Switch Operation

The Wall Switch can be used to control your fireplace. You can turn the pilot on or off and you can increase or decrease the flame height.

Note that the thermostat and programming functions are not available with the wall switch.



## Adjusting Flame Height

Press and hold large flame button to gradually increase flame height.

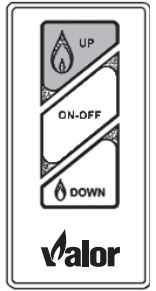

## Turning Appliance ON and OFF

Press ON-OFF button once to light pilot. Press again to shut off pilot.

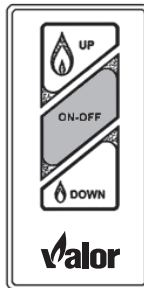

Press and hold small flame button to gradually decrease flame height.

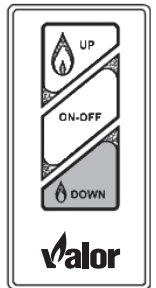

# Appendix D - HeatShift System

# HeatShift™ System

## Planning Installation: LX2 with HeatShift®

Planning for use with the following **Valor Heater Models ONLY: 2200J, 2200K**

### Application

The HeatShift® convection duct kit redistributes the warm air flow away from the fireplace opening to a more desirable location using natural convection without use of a fan.

**Plenums LKD1, LDK3, LDK4 or LDK9:** the warm air flow is relocated to a position higher up the wall, out the sidewalls, or even to an adjacent room.

**Termination Plates LDK7:** the warm air flow is discharged through a gap (min. 2-1/2") between the wall above the fireplace and the ceiling. **LDK7's discharge opening must be located in the same room as the fireplace.**

The result is much cooler wall temperatures above the fireplace opening for locating televisions, artwork, etc. Any kit, LDK1, LDK3, LDK4, LDK7 or LDK9 may be used on LX2.

### Approvals

The LDK1, LDK3, LDK4, LDK7 and LDK9 duct kits are CSA approved for use only with Valor Series fireplaces listed above—DO NOT use with any other models.

5-inch diameter duct used with this kit must be metal and meet requirements of UL-181 Class 1 Air Duct. Flexible aluminum duct is acceptable provided it meets the UL-181 Class 1 requirements.

Note: These instructions are to be used in conjunction with instructions regarding fireplace installation in this manual.

### Kits

There are 4 kits to choose from:

- LDK1—48" Plenum
- LDK3—14" Plenums (2), includes grilles
- LDK4—38" Plenum
- LDK7—Duct Termination Plates (2)—for wall valance discharge ONLY
- LDK9—30" Plenum

### Optional accessories

- LDK2—48" Finishing Frame, to use with LDK1
- LDK5—38" Finishing Frame, to use with LDK4
- LDK6— 5" dia Aluminum 2-ply Flex Kit— 2 x 10'-0" lengths, may be cut to required length
- LDK10—30" Finishing Frame, to use with LDK9

### **WARNING**

**When placing discharge close to ceilings, staining or streaking may occur on light colored ceilings due to any dust, etc. in air flow; placing plenum(s) lower on the wall will help reduce the possibility of staining or streaking.**

### **WARNING**

**DO NOT cover or place objects in front of or on top of air outlet(s). AVOID locating outlet within 7 feet above floor level as discharge temperatures are hot!**



# Appendix D - HeatShift System

## Kits Contents

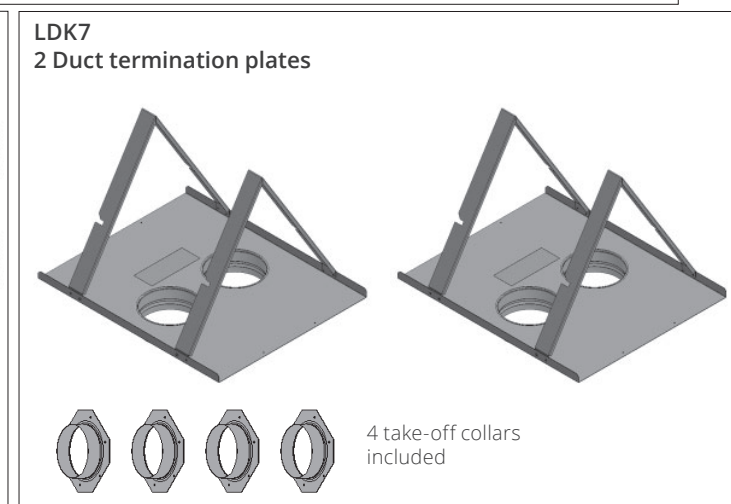
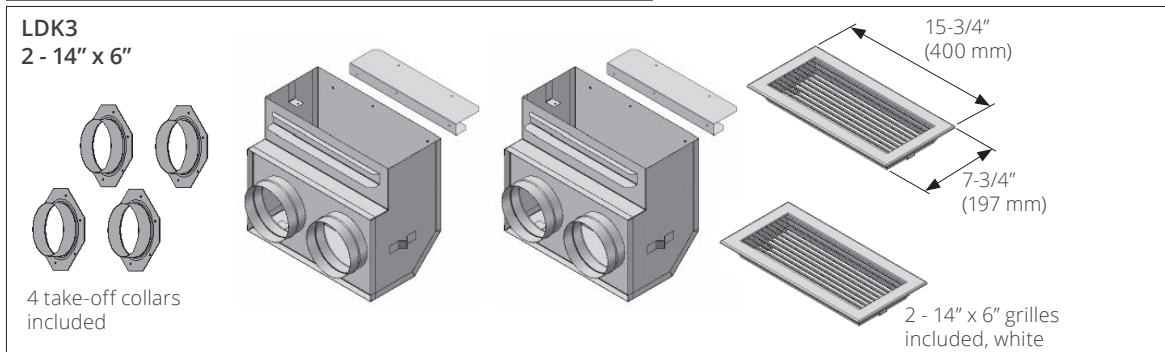
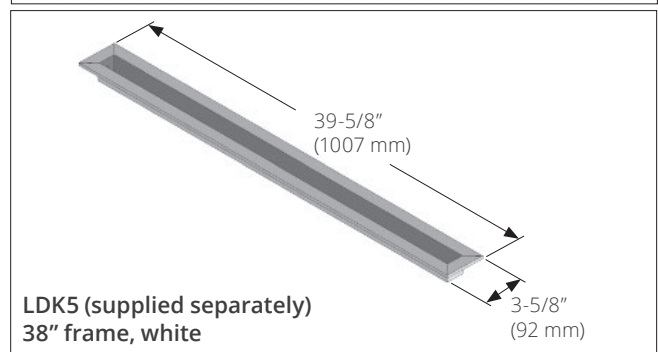
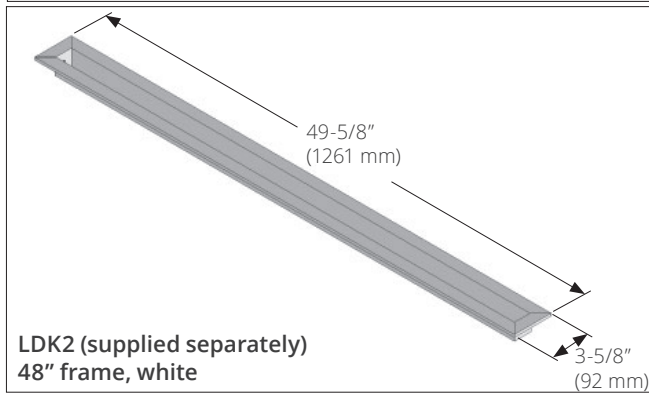
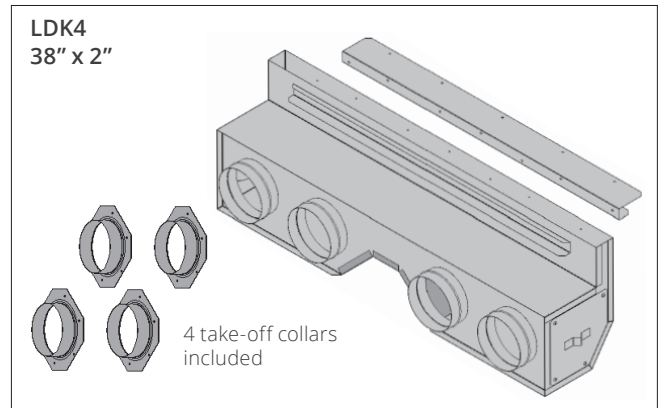
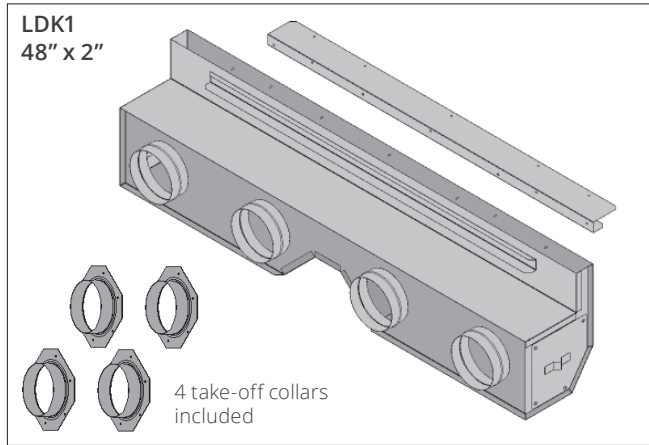

# Appendix D - HeatShift System

## Kits Contents (cont'd)

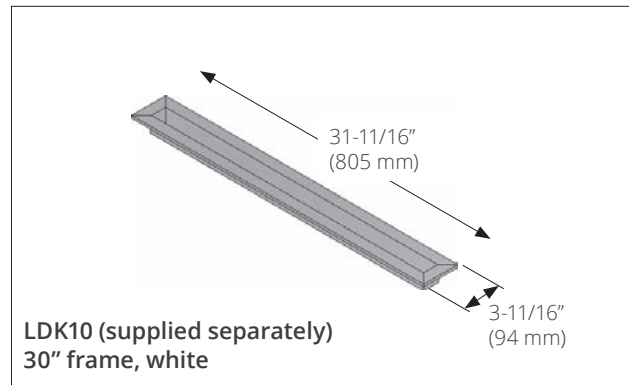
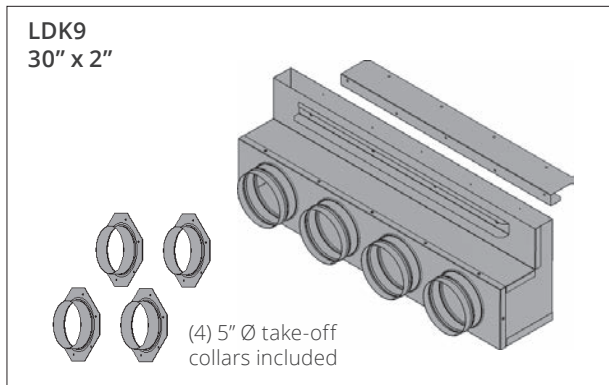

## Suggested Configurations Not to scale

### LX2 Series

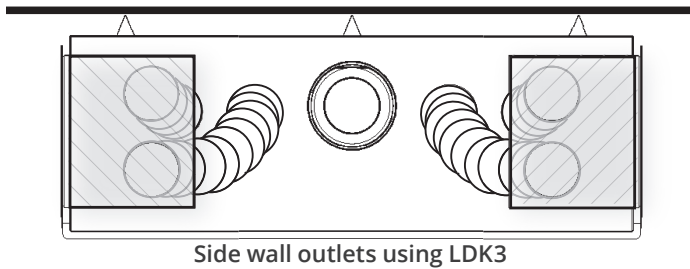

Note - When using LDK7, the discharge opening must be located in the same room as the fireplace.

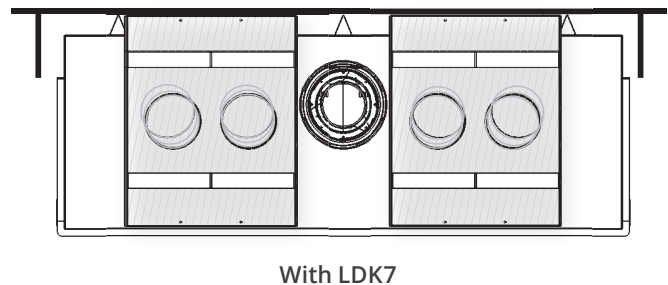

Note - Vertical 6-5/8" venting straight off the 2200 will pass by notched plenum without offsetting the vent. If using 8" vertical venting, a 20" deep cavity may not accommodate the plenum. Adjust cavity depth accordingly.

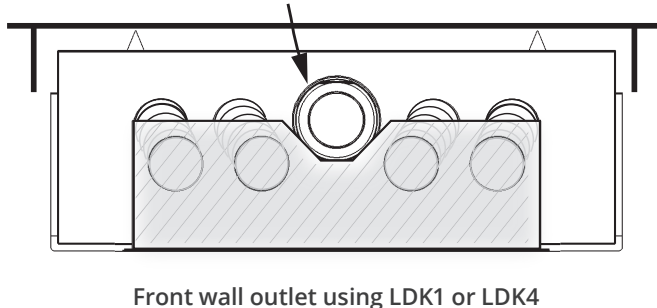

## **⚠ WARNING**

The plenum duct kits are approved for horizontal discharge ONLY. The termination duct plates are approved for vertical upward discharge ONLY. DO NOT install plenum or termination plates in floor or ceiling. DO NOT COVER OR PLACE objects in front of or on top of air outlet(s). AVOID locating outlet within 7 feet of the floor level as discharge air temperatures are hot!

**DO NOT DISCHARGE THROUGH EXTERIOR WALLS!**

# Appendix D - HeatShift System

Overview (applies to LKD1, LDK3, LDK4 and LDK9 kits)

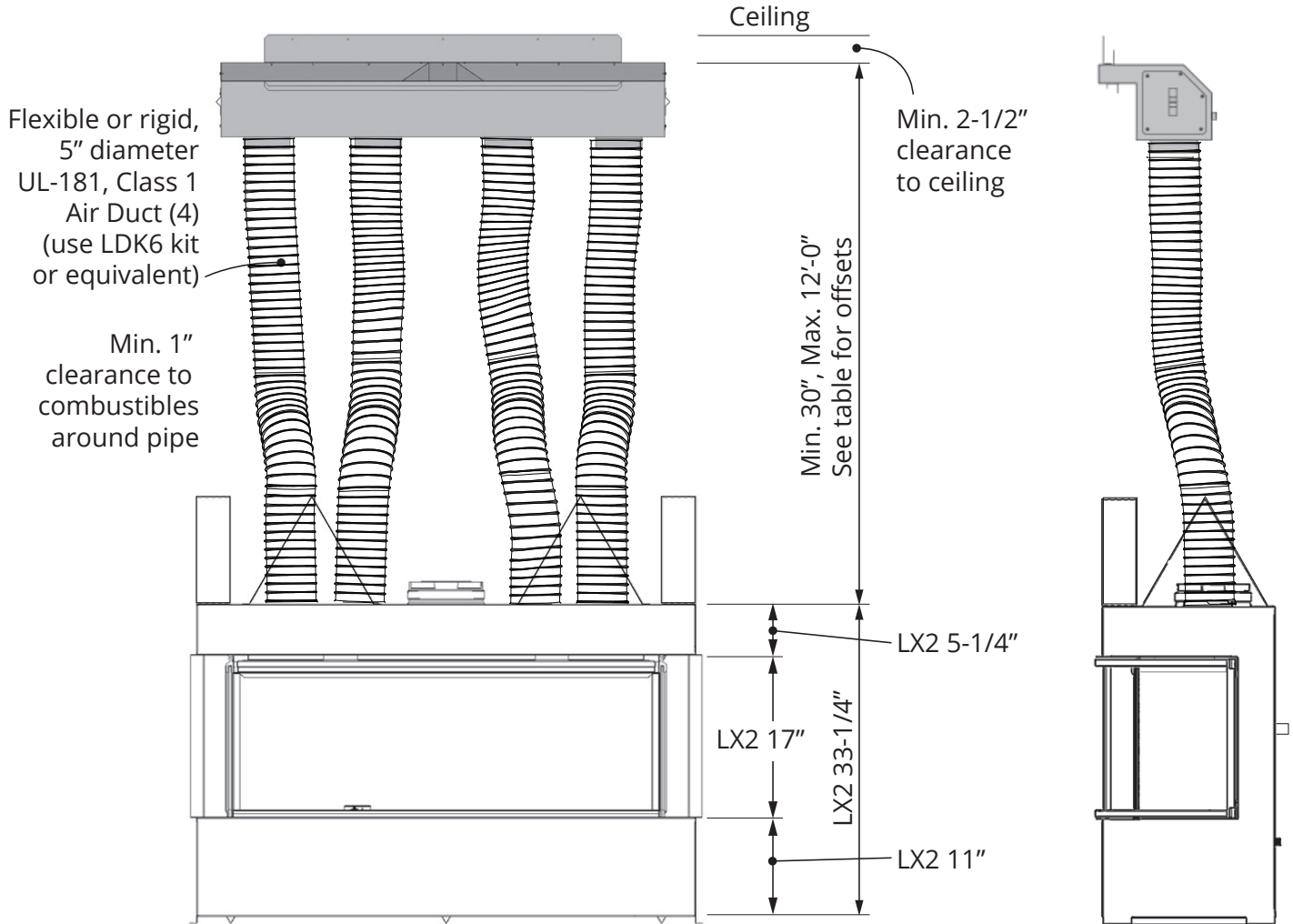

# Appendix D - HeatShift System

Overview (applies to LDK7 kit)

Note - Discharge opening must be located in the same room as fireplace when using LDK7.

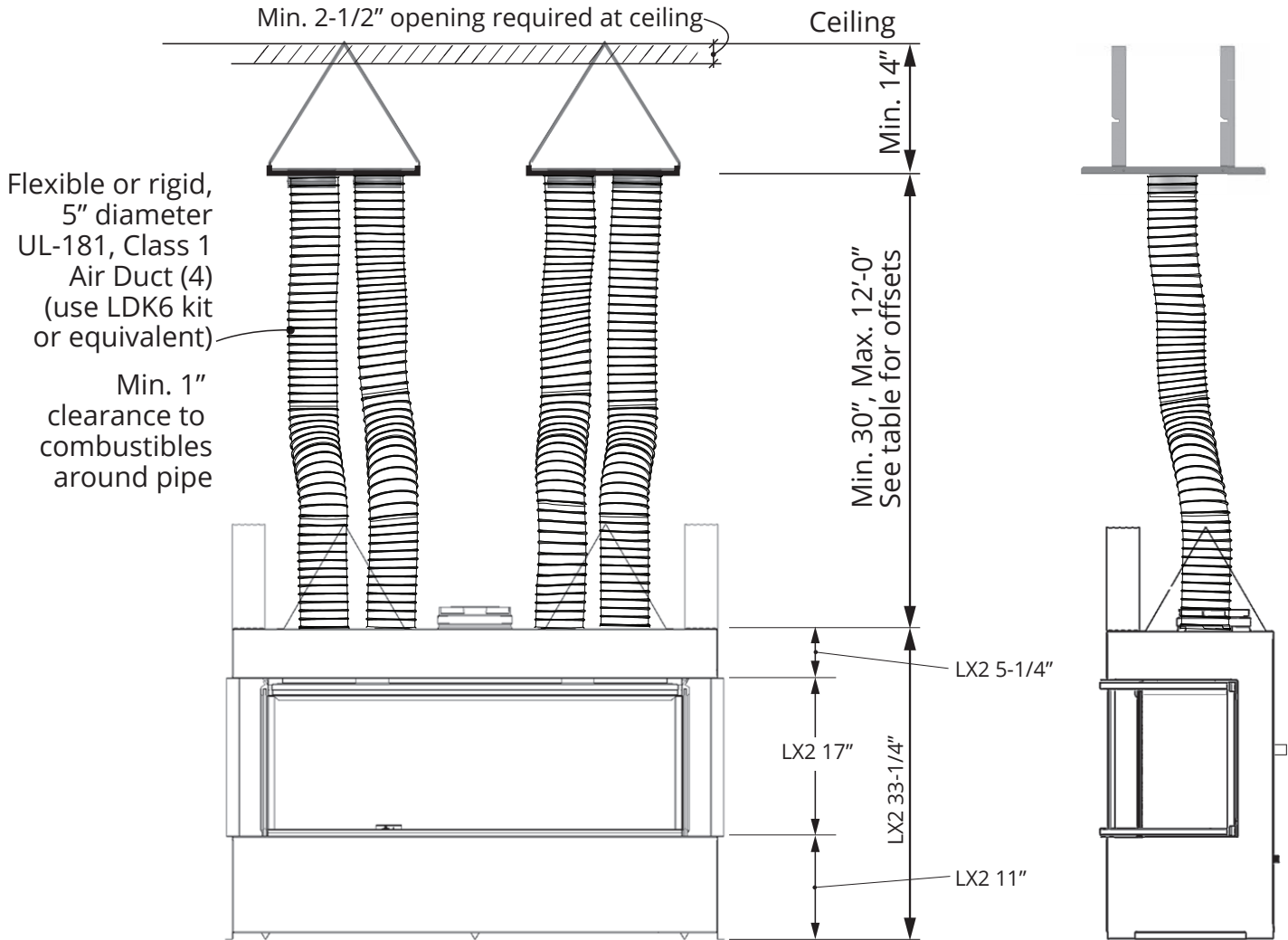

# Appendix D - HeatShift System

Y Vertical Rise	X Max. Allowable Horizontal Offset
30"	24"
36"	36"
42"	48"
48"	60"
54"	72"
60"	84"
66"	96"
12'-0"	96" Max.

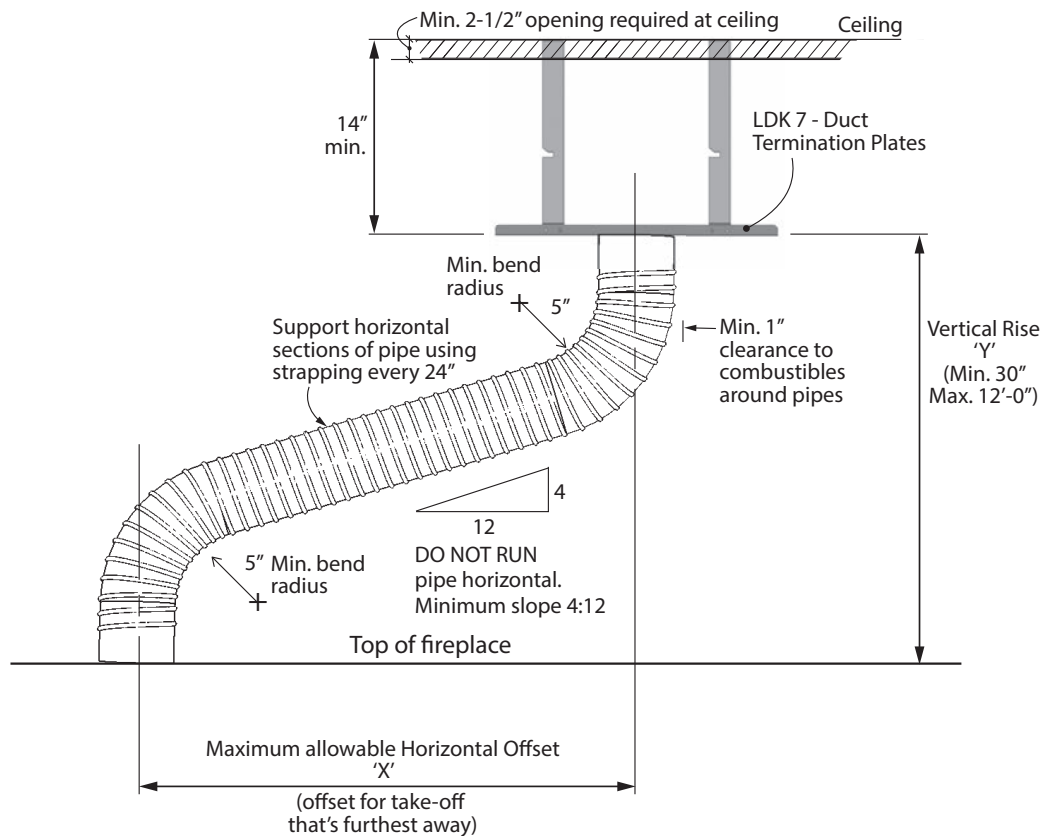
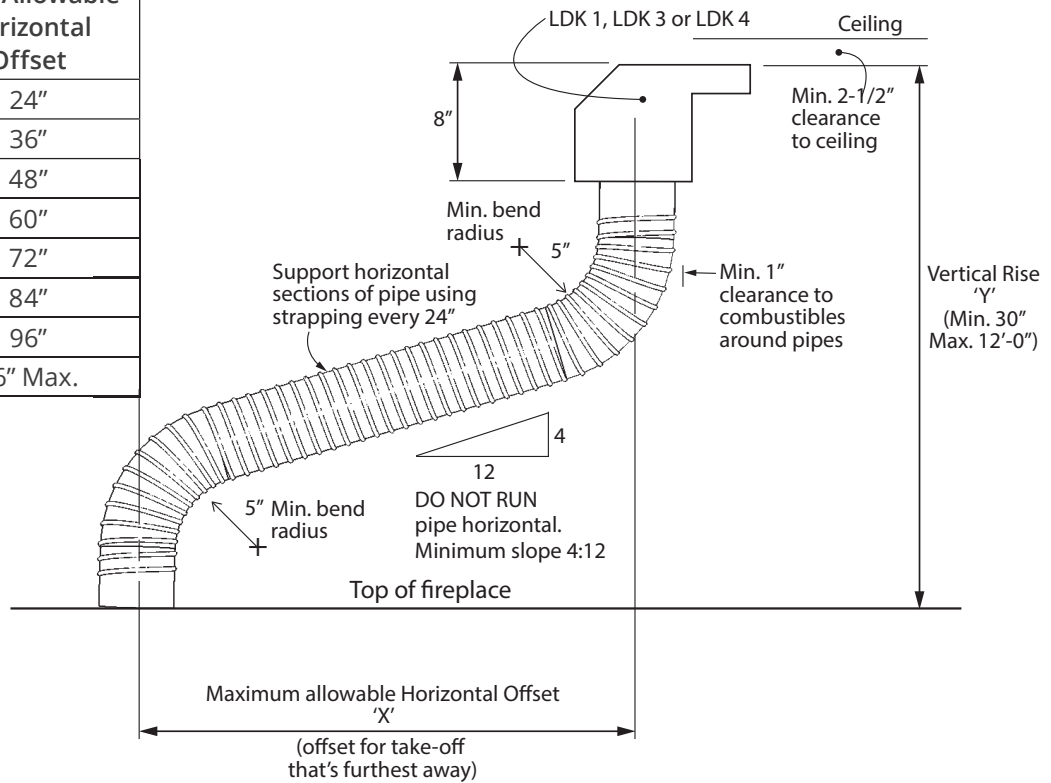

# Appendix D - HeatShift System

## Plenum Dimensions

LDK 1

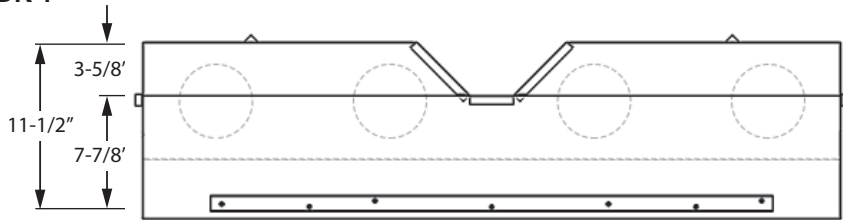

Top View

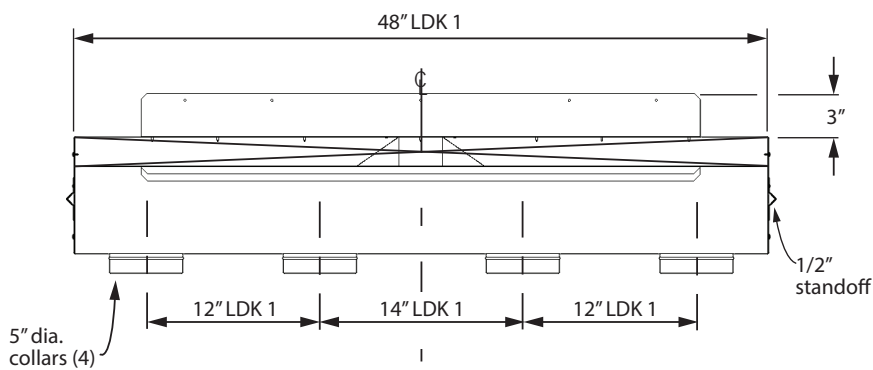

Front View

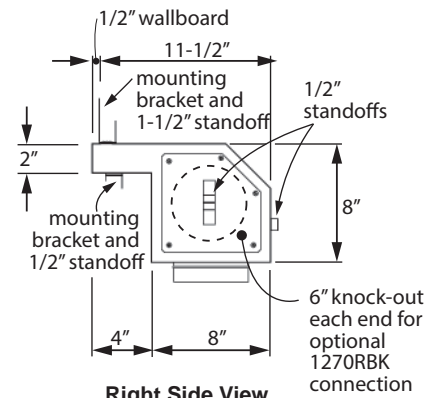

Right Side View

LDK 4

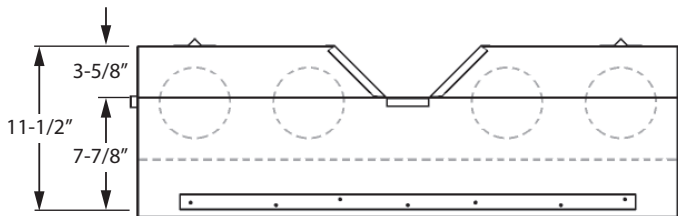

Top View

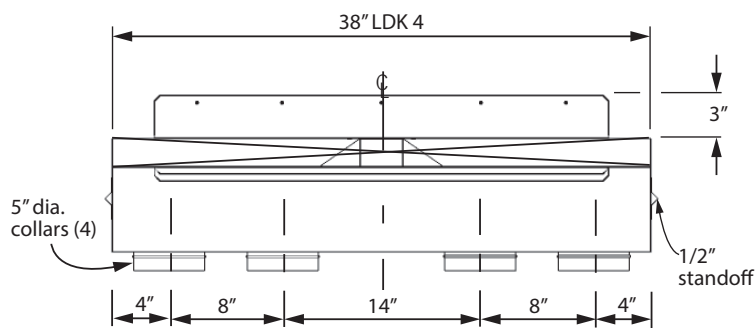

Front View

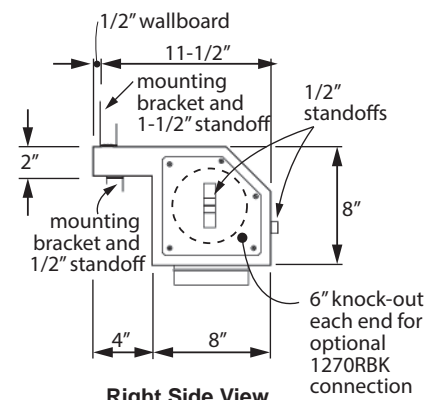

Right Side View

# Appendix D - HeatShift System

## Plenum Dimensions (cont'd)

LDK 3

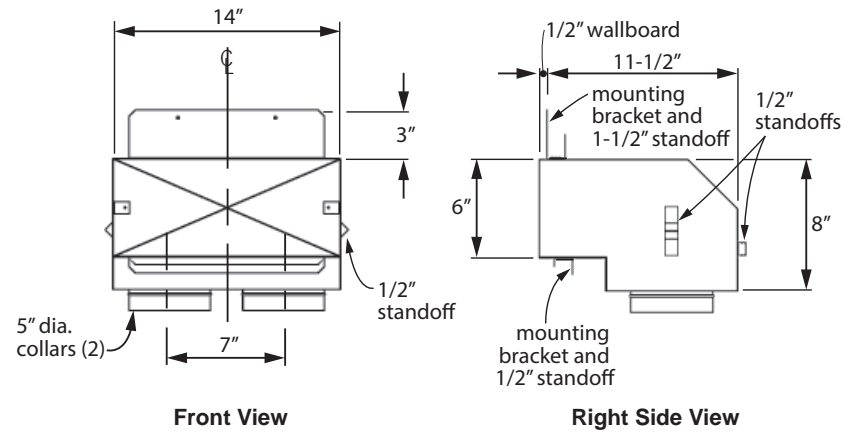

LDK 9

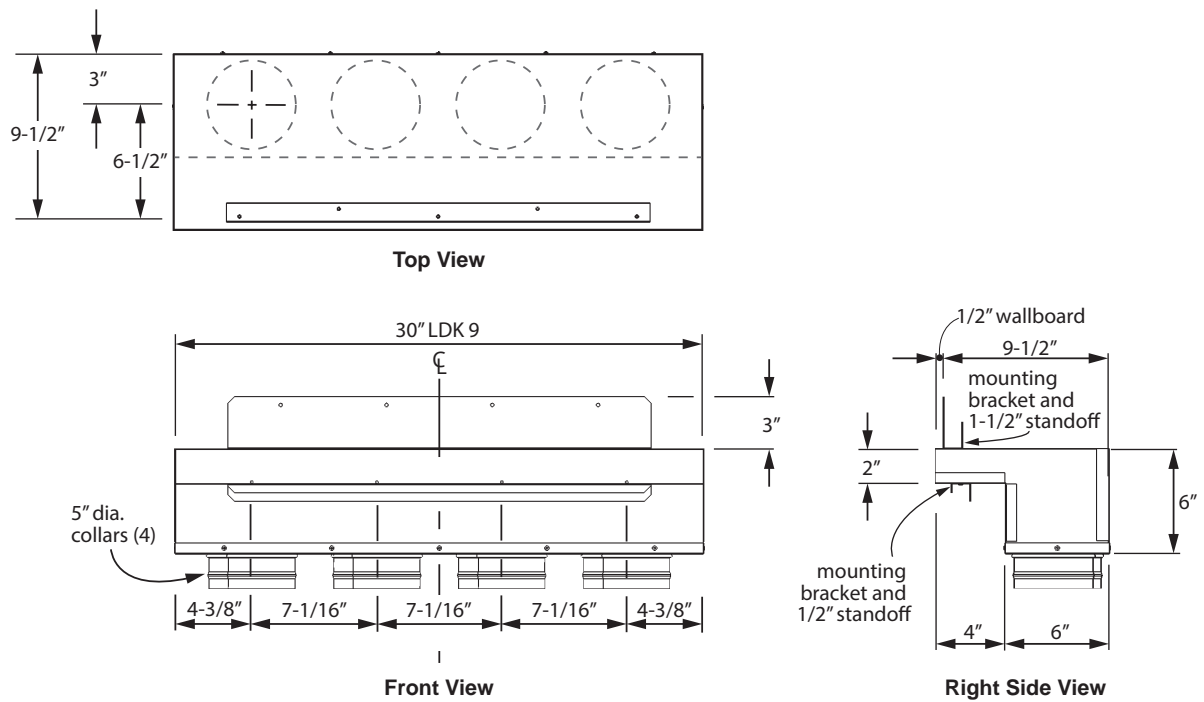

# Appendix D - HeatShift System

## LDK7 Plates Dimensions

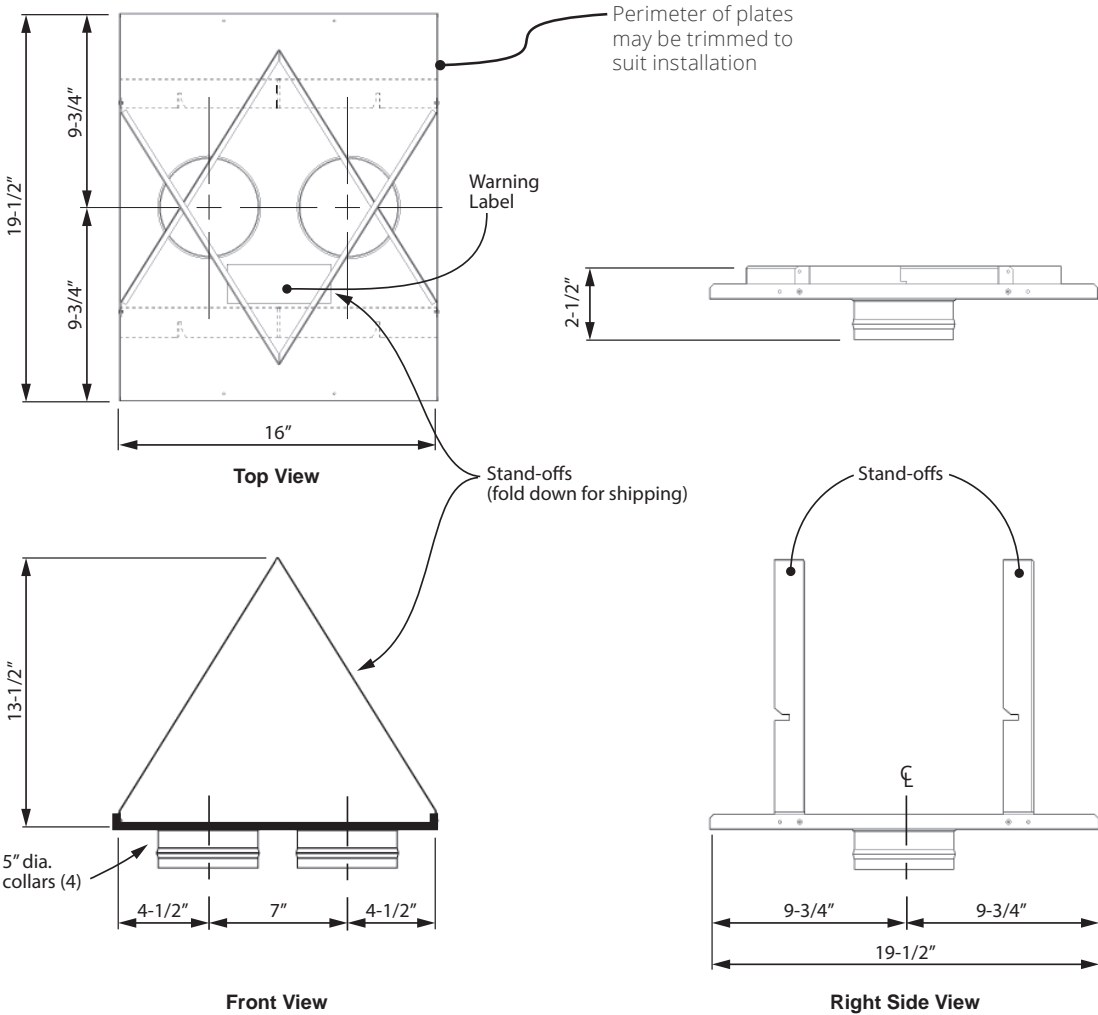



# Appendix D - HeatShift System

## Rough Frame Openings

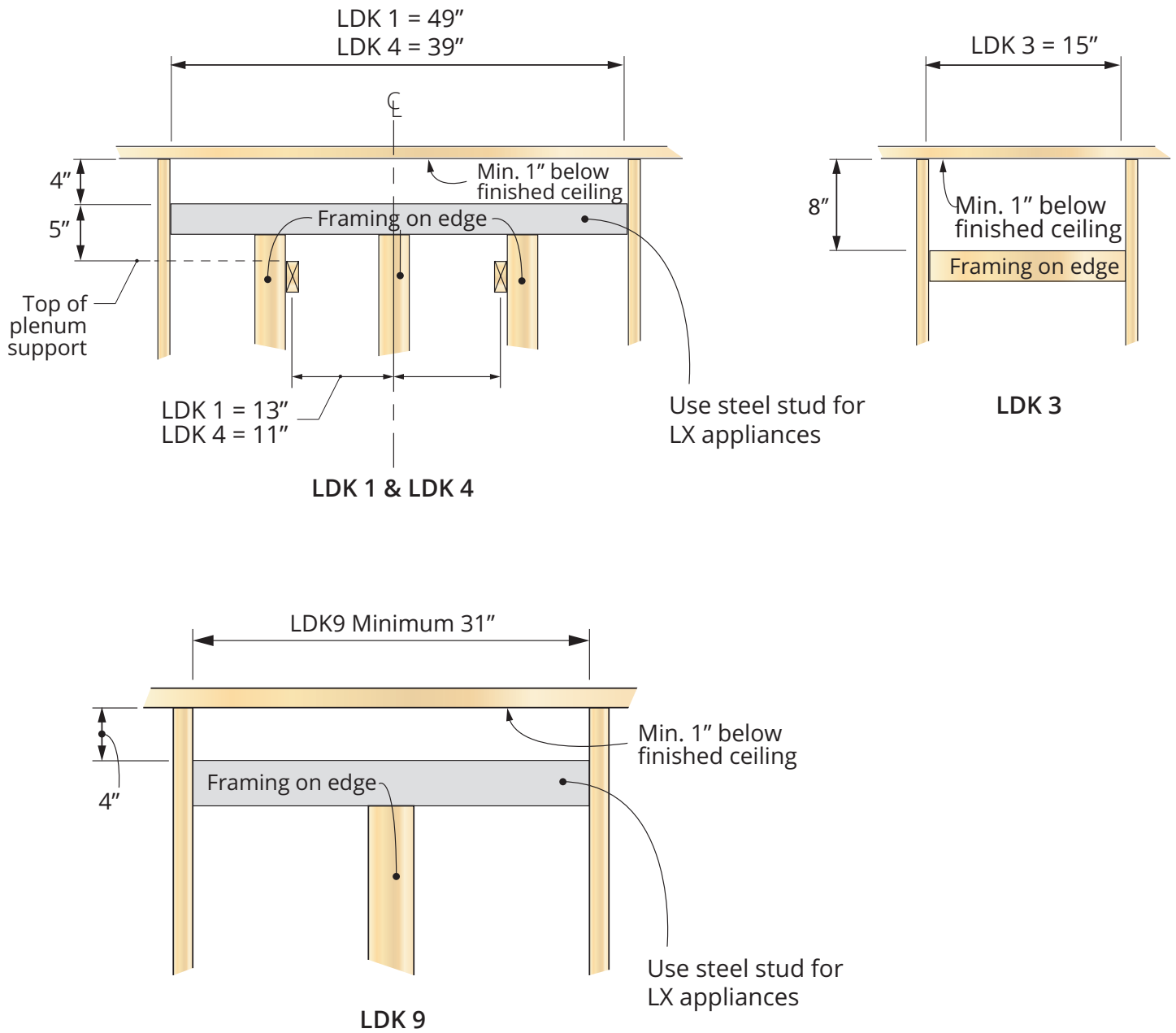

# Appendix D - HeatShift System

## Framing and Clearances

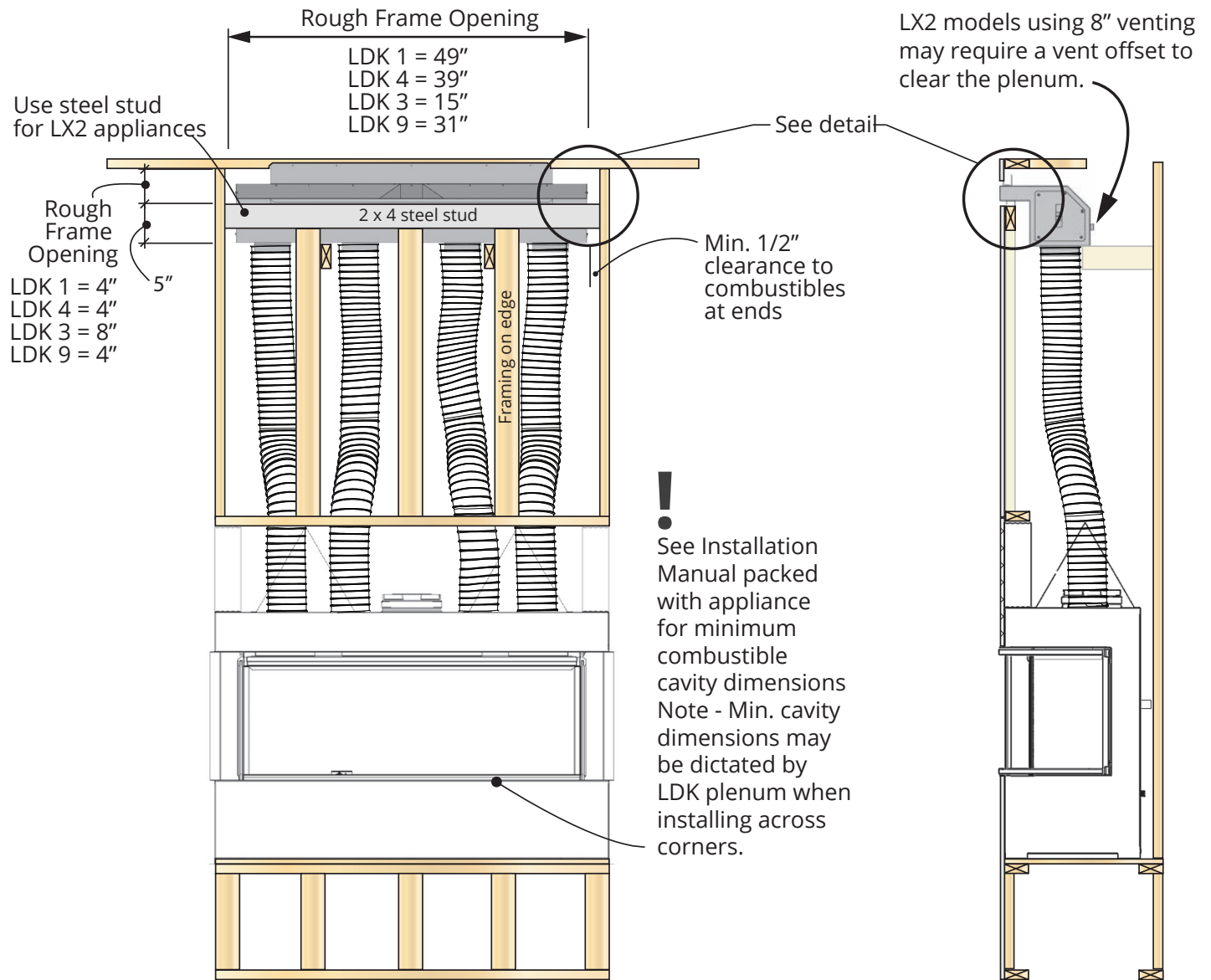

# Appendix D - HeatShift System

## Framing and Clearances

### LDK 1 & 4

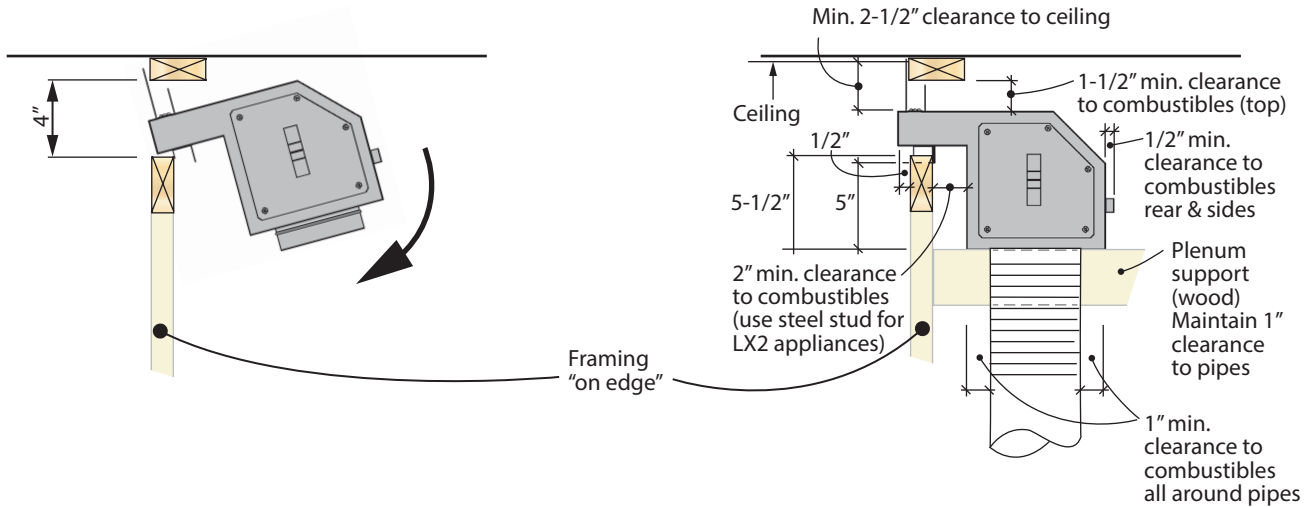

### LDK 3

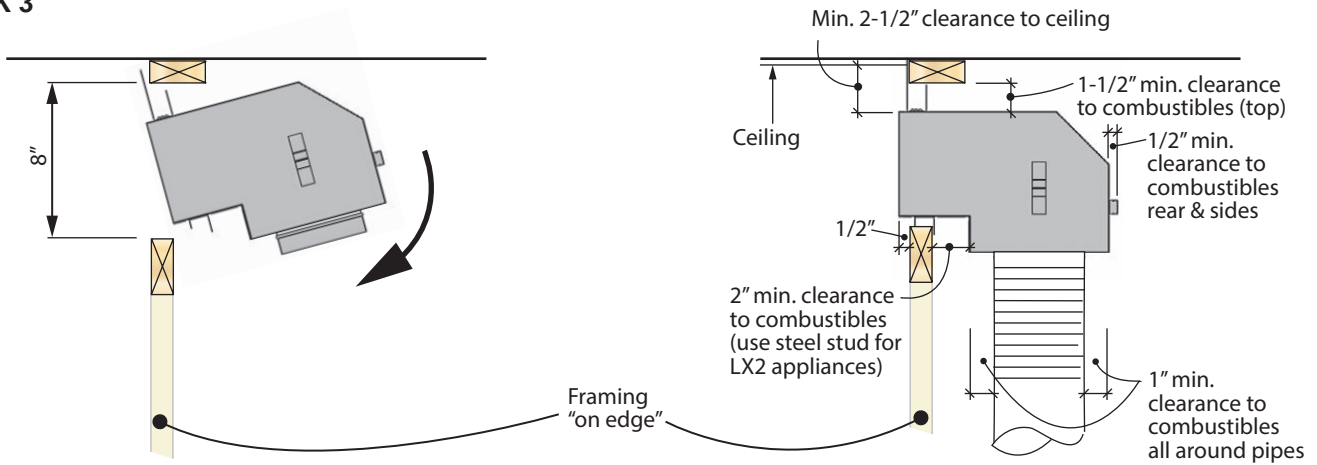

### LDK9

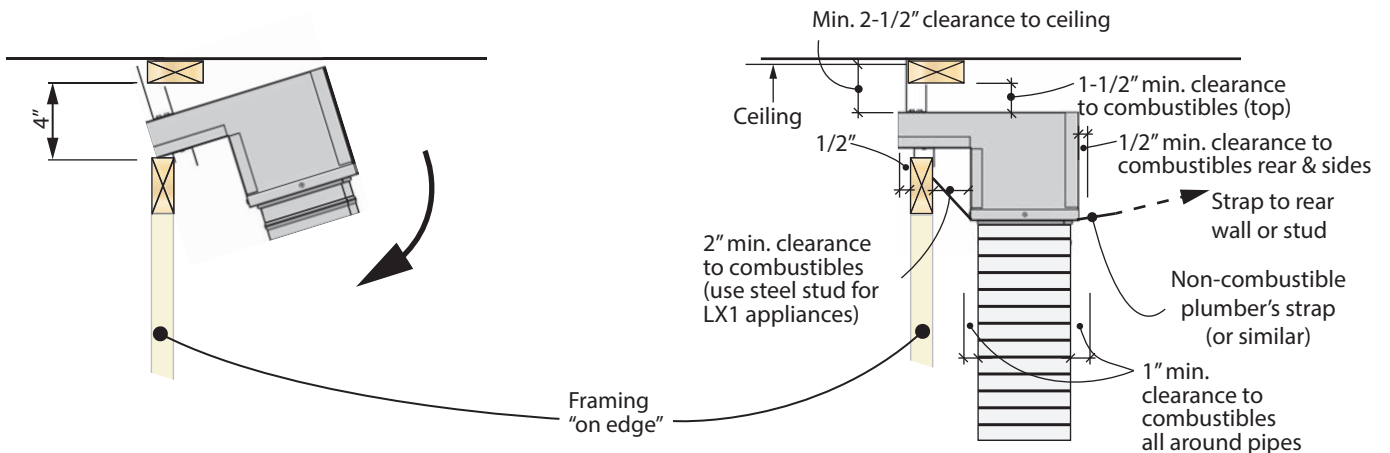

# Appendix D - HeatShift System

## Wall Valance Discharge Opening using LDK7—Duct Termination Plates

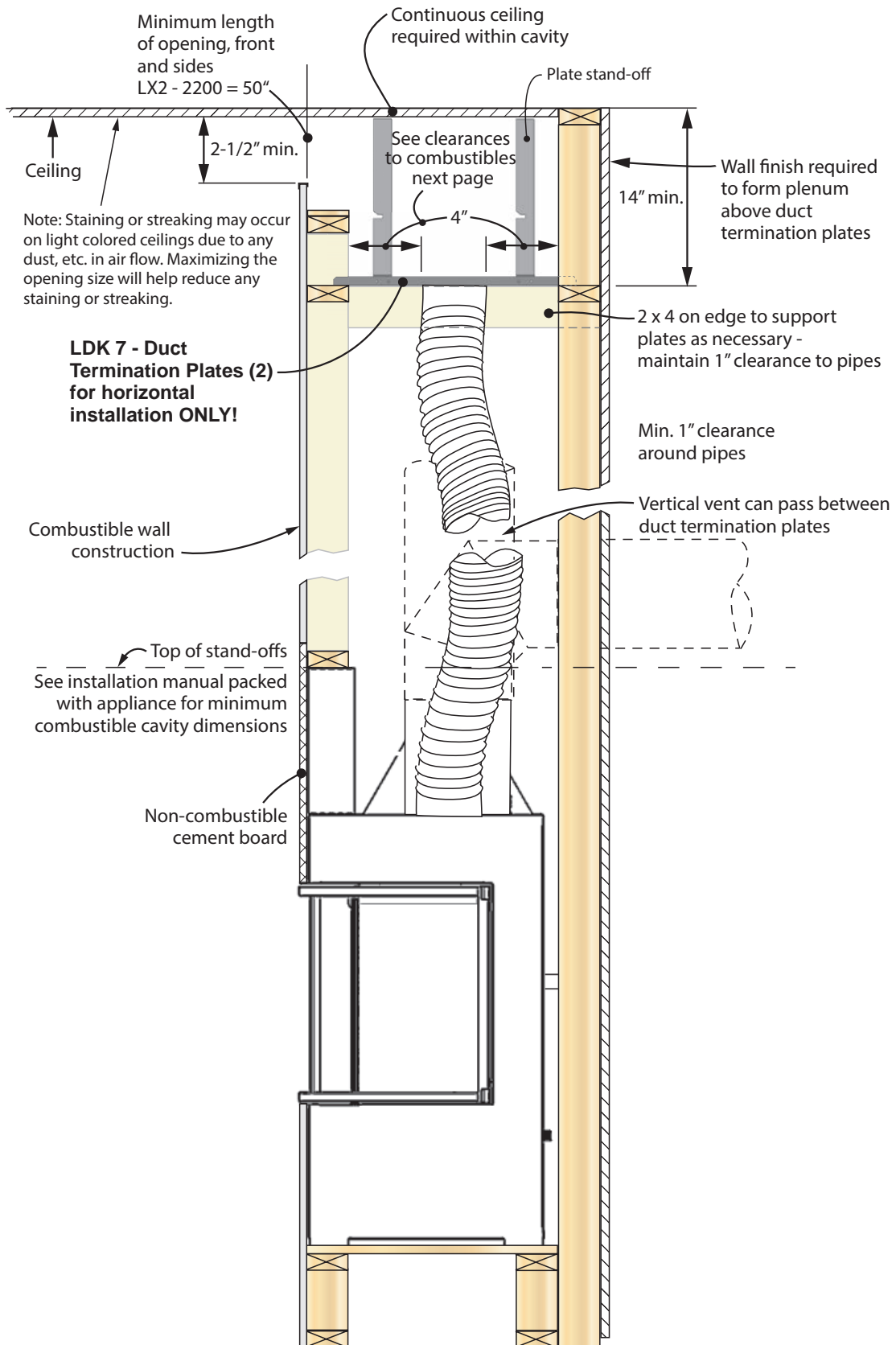

# Appendix D - HeatShift System

## LDK7 Clearances to Combustibles

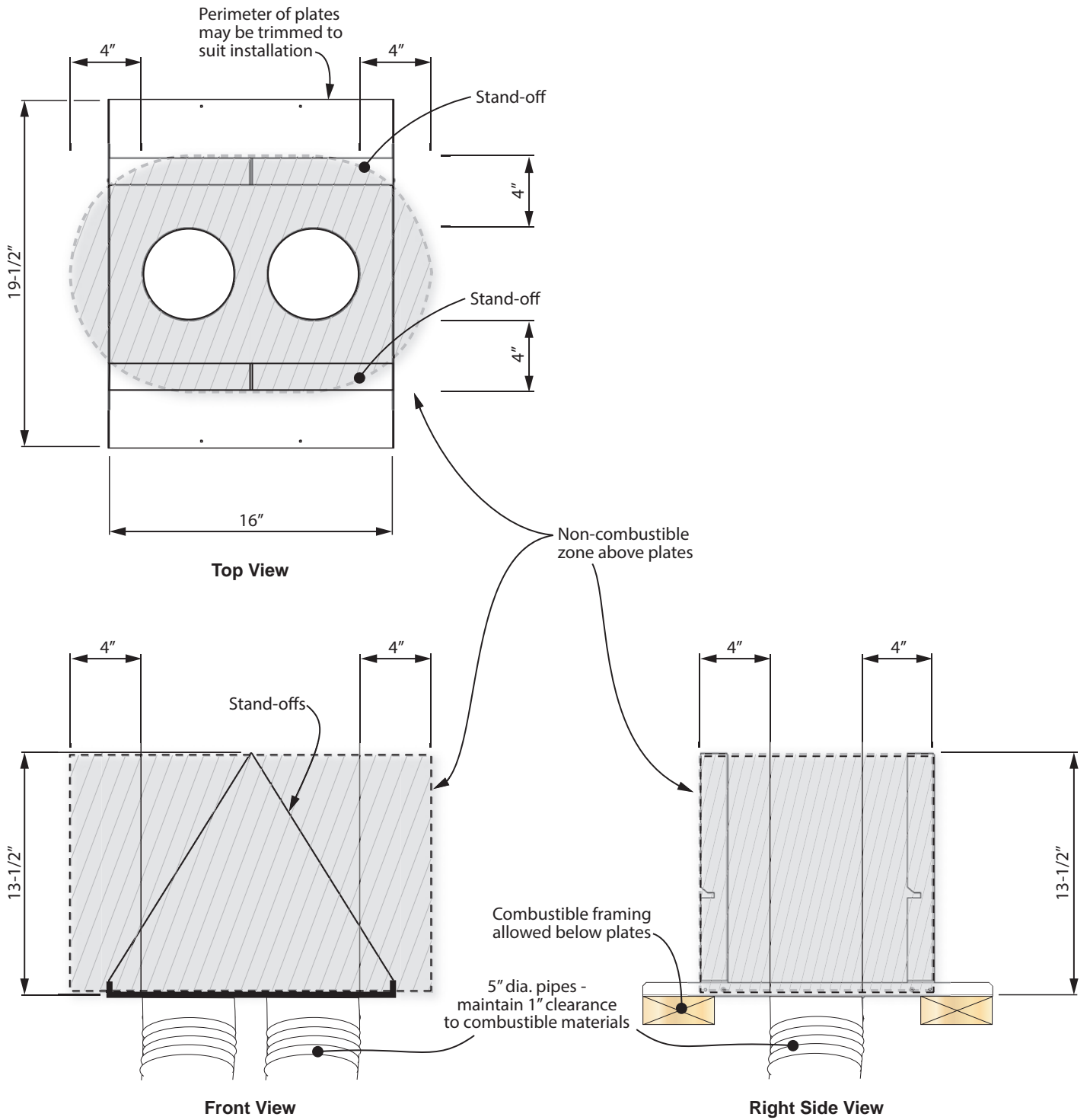

# Appendix D - HeatShift System

## **WARNING**

**All FOUR (4) takeoffs MUST BE CONNECTED TO PLENUM(S).**

Install Plenum Kits (LDK1, LDK3, LDK4 & LDK9)  
—see next page for LDK7 Duct Termination  
Plates

1. Install 4 collars supplied with plenum to appliance.

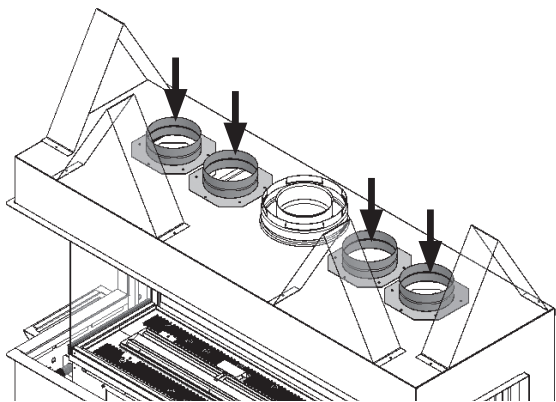

2. Frame a rough opening at the desired location—see earlier sections of this manual for allowable plenum positions and rough frame opening sizes.
3. Install top mounting bracket(s) to the plenum using screws provided (use the short sheet metal screws provided otherwise the screw tails (ends) will interfere with the finishing frame when installed).

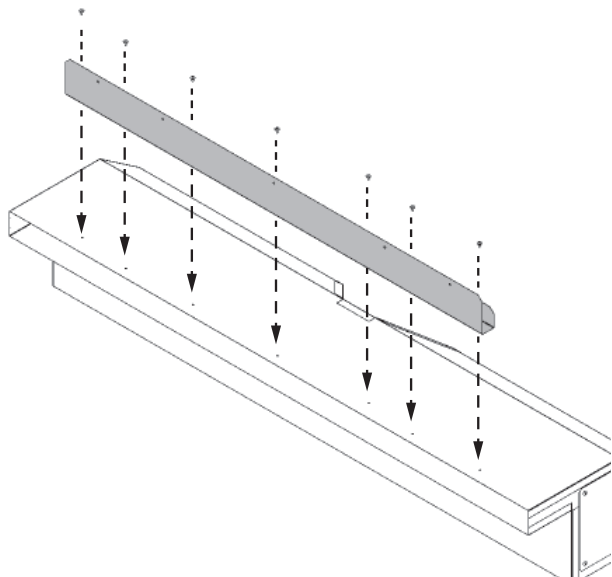

4. Install the plenum(s) into the rough frame opening maintaining minimum clearances to combustibles as listed—see Rough Frame Openings. Fix the plenum to the framing using nails or screws through the top mounting bracket. **Note that the mount-**

ing brackets are not intended to carry the weight of the plenum and pipes. Provide support to the underside of the plenum and ensure the plenum is level and its outlet is not distorted (see Framing and Clearances). Use metal strapping (all-round, not supplied) as required to further secure the plenum to framing.

5. Attach one section of UL-181, Class 1 approved air duct to each of the collars and secure it with gear clamps provided. **DO NOT SPLICE DUCTS!**
6. Attach the top of the pipe sections to the plenum securing them with the gear clamps provided. An upward slope must be maintained in horizontal sections of pipes for proper convection. Use straps as necessary to maintain the pipes positions. Support horizontal sections every 24 inches.
7. Paint the inside surfaces of the plenum using high-temperature flat black spray paint for installations where the inside of the plenums may be visible. **Note:** The flanges of the white finishing frame (when used) will insert approximately 1-1/4" into the plenum covering the shiny sheet metal.
8. Install the finishing frame or louver to the plenum after the wall finish is completed:  
**LDK1, LDK4, LDK9:** Use the LDK2, LDK5 or LDK10 depending of the length of the plenum.

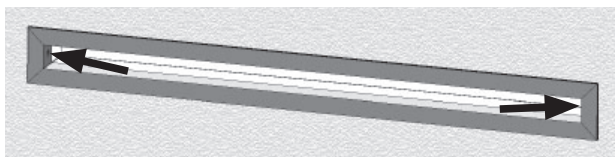

**LDK3:** Use the grilles provided with the kit.

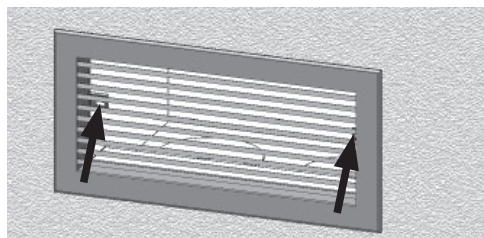

**Note:** The frame/louver are finished white but may be painted another color if desired; use high temperature paint (250°F). You may also finish up to the perimeter of the plenum opening with your material of choice and not use the frame or louver. Do not finish over any of the opening in the plenum outlet.

9. Continue with the fireplace installation.

# Appendix D - HeatShift System

## **⚠ WARNING**

**All FOUR (4) takeoffs MUST BE CONNECTED TO PLENUM(S).**

### Install Duct Termination Plates (LKD7) —see previous page for LDK1, LDK3, LDK4 & LDK9 Plenum kits

1. Install 4 collars supplied with plaques to appliance.

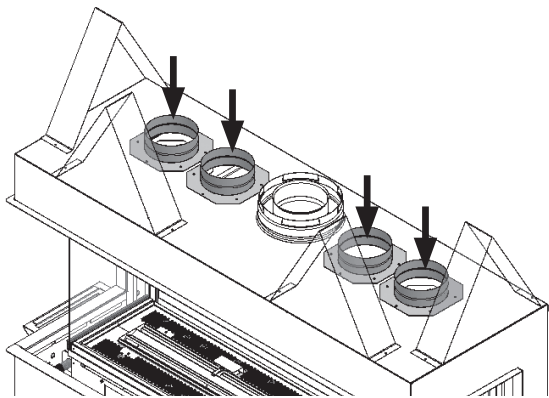

2. Frame a rough opening and platform at the desired location—see earlier sections of this manual for allowable duct termination plates positions and rough frame opening sizes.
3. On each duct termination plate, rotate both stand-offs to the vertical position and secure in place using screws provided.

2 stand-offs per plate

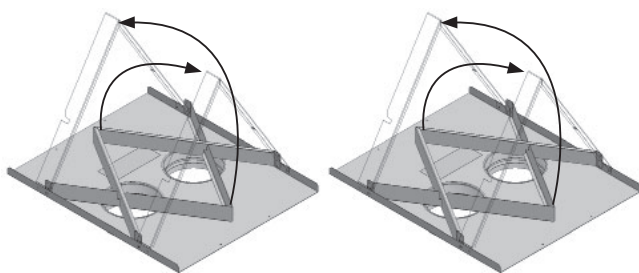

4. Install the termination plates into the framing ensuring collars/pipes on underside of plates maintain 1 inch clearance to combustibles and clearance to combustible above the plates are maintained as listed in preceding pages.

The termination plates perimeter may be trimmed as necessary to accommodate framing. Secure the termination plate to framing using screws or nails to avoid movement.

5. Attach one section of UL-181, Class 1 approved air duct to each of the collars and secure it with gear clamps provided. **DO NOT SPLICE DUCTS!**

6. Attach the top of the pipe sections to the duct termination plates securing them with the gear clamps provided. An upward slope must be maintained in horizontal sections of pipes for proper convection. Use straps as necessary to maintain the pipes positions. Support horizontal sections every 24 inches.
7. Continue with the fireplace installation.

### Repair Parts List

	Description	Part no.
<b>LDK1</b>	48" Quad Hot Air Plenum Kit	
	48" x 2" quad plenum	4005476
	5" take-off collars (4)	4005478
	Top mounting bracket/standoffs	4007211
	#8 slotted drive screws 1/4" (7)	798601
<b>LDK2</b>	48" Outlet Frame Kit for LDK1	
	Aux Frame-SPL 48" x 2" white	4005612
<b>LDK3</b>	14" Double Hot Air Plenums Kit	
	14" x 6" double plenums (2)	4005464
	5" take-off collars (4)	4005478
	DABL-00-C-SPL 14" x 6" Grilles white (2)	4005614
	Top mounting bracket/standoffs (2)	4005566
	#8 slotted drive screws 1/4" (6)	798601
<b>LDK4</b>	38" Quad Hot Air Plenum Kit	
	38" x 2" quad plenum	4005477
	5" take-off collars (4)	4005478
	Top mounting bracket/standoffs	4007213
	#8 slotted drive screws 1/4" (7)	798601
<b>LDK5</b>	38" Outlet Frame Kit for LDK4	
	Aux Frame-SPL 38" x 2" white	4005613
<b>LDK6</b>	5" Aluminum 2-ply Flex Kit	
	5" dia 10' (uncompressed) aluminum chimney liners (2)	4005635
	4.5" - 6.5" ss gear clamps (8)	4005642
<b>LDK7</b>	Duct Termination Plates	
	Plate and collar assembly (2)	4006747
	5" take-off collars (4)	4005478
	Screws 8 x 3/8 tap PN HD PH (12)	100A757
<b>LDK9</b>	30" Quad Hot Air Plenum Kit	
	30" x 2" quad plenum	4007903
	5" take-off collars (4)	4005478
	Top mounting bracket/standoff	4007601
	#8 slotted drive screws 1/4" (5)	798601
<b>LDK10</b>	30" Outlet Frame Kit for LDK9	
	Aux Frame-SPL 30" x 2" white	4007951

Each LDK kit is sold separately.

# Appendix E - Spare Parts

	Description	Part No.
1	Vent reducer - converts to 4 x 6-5/8"	58DVA-X46
2	Window assembly - left - LJN/LJP	4005724
	Window assembly - right - RJN/RJP	4005723
3	Side screen assembly	4006888X
4	Exhaust restrictors (2)	4005911
5	Rear panels retaining brackets (3)	4005907
6	End panel retaining bracket	4006740
7	Wire cover	4006270
8	Electrical passage gasket	4006274
9	Burner assembly	4006942AH
10	Media tray - rear	4005939AH
11	Pilot cover	4005940AH
12	Media tray - front	4005938AH
13a	Door gasket - front	4006238A
13b	Door gasket - side	4006238B
14	Window assembly - front	4005722
14a	Bottom cover (corner right units ONLY)	4006964
14b	Bottom cover (corner left units ONLY)	4006967
15	Silicone window seals (2)	4005846
16	Door handle	4006269
17	Door retainer assembly (2)	4005913
18	Hot Glass warning plate	4003093
19	Light assembly - upper	4005725
20	Bi-pin halogen bulb GY6.35 20 W (3)	4005700
21	Front screen assembly	4006797X
22	Burner module assy - natural gas	4006685KS
	Burner module assy - propane gas	4006154KS
23	Pilot assembly (natural gas)	4006738
	Pilot assembly (propane gas)	4006739
24	Plug pilot	4000726
25	Pilot injector #51 (natural gas)	4000735
	Pilot injector #30 (propane gas)	4000736
26	Pilot injector #51 (natural gas)	4000735
	Pilot injector #30 (propane gas)	4000736
27	Thermocouple	4000061
28	Pilot tube	4000732
29	Pilot hood 2-flame	4000730
30	Extended nut	4001855
31	Electrode	4001856
32	Gas orifice DMS #32 (natural gas)	4007000-32
	Gas orifice DMS #49 (propane gas)	4007000-49
33	Pilot gaskets (2)	4000715
34	Pilot stand extrusion	4006649
35	Air shutter	4006594
36	Air shutter arm	4006582

	Description	Part No.
37	Pivot bracket	4006583
38	Module tray gasket - long (2)	4006256
39	Module tray gasket - short (2)	4006257
40	Block/pipe connector	4006689
41	Gas supply line	4006688
42	Flex line c/w flare to flare fittings	4000345
43	GV60 Gas valve assy - natural gas	4003986X
	GV60 Gas valve assy - propane gas	4003987X
44	Thermocurrent interruptor	4001037
45	Nut olive - pilot fitting	220K913
46	V-Module	4002530
47	Receiver 'CC' 2-way	4005597
48	Wire harness GV60	4001187
49	Yellow cable to interrupter	4002096
50	Red cable to interrupter	4001035
51	Ignition cable sleeve 530 mm	4002244
52	Ignition cable 500 mm	4001039
53	Comfort Control wall holder	4004459
54	10-button SYMAX handset black	4007548
55	Remote Battery & Wall Switch Kit	RBWSKX
55a	Junction box	4005527
55b	Cover plate & 4 screws	4005526
55c	Battery holder	4005525
55d	Cable tie	4005524
55e	Harness assembly	4005523
55f	Plate with magnets	4005391
55g	Long screws (4)	4001444
55h	Wall switch with 2 screws	4005522
55i	Battery cover assembly	4005390
56	Ceramic liner panels - complete set	
	Fluted Black Liners	2200FBL
	Limestone Liners	2200LML
57	Rear panel—center	
	Fluted Black	4005943
	Limestone	4005779
58	Rear panel—sides	
	Fluted Black (2)	4005941
	Limestone (2)	4005778
59	Ceramic panel retainers	
	Fluted Black (2)	4006499BY
	Limestone (2)	4006499BY
60	Reflective Glass Liners	2200RGL
61	Panel retainers (3)	4006500BY
62	Glass panels (3)	4005845



# Appendix E - Spare Parts

	Description	Part No.
63	End panel (LJ and RJ appliances)	
	Fluted black end panel	2200FBP
	Limestone end panel	2200LMP
64	Reflective glass end panel	2200RGP
65	Murano Glass Set	2200DGM
66	1/2" clear fireglass	4004521
67	1/4" ceramic pads (8)	4006367
68	Murano glass platform - front	4005729
69	Murano glass platform - rear	4005738
70	Decorative Glass Set	2200DGS
71	1/2" clear fireglass (4 bags)	4004521
72	Long Beach Driftwood Kit	1705DWK
73	Rear log	4002938
74	LH end log	4002965
75	LH front log	4002967
76	Center cross log	4003721
77	RH rear log	4003928
78	RH Cross log	4003929
79	Brown beach pebble	4003082
80	Grey beach pebble (2)	4003083
81	Small grey beach pebble	4003086
82	White beach pebble (2)	4003084
83	Black beach pebble (2)	4003085
84	Small beige beach pebbles (2)	4003087
85	Grade 1A vermiculite, bagged	4002940
86	Rocks & Shale Set	1714RSS
87	LH twig	4001827
88	LH twig - short (2)	4001827S
89	RH twig (2)	4001828
90	Grey Rock S4-A (7)	4002338
91	Dark Grey Rock S4-A (5)	4002339
92	Grey Rock S4-B (5)	4002340
93	Dark Grey Rock S4-B (8)	4002341
94	No 7 Grey 5 Matte pitted rock	4002650
95	No 9 Grey 5 Matte rock (2)	4002652
96	No 11 Grey 3 Matte rock (2)	4002654
97	No 14 Grey 9 Gloss rock	4002657
98	No 16 Warm Grey 3 Gloss pitted rock (2)	4002659

	Description	Part No.
99	No 17 Grey 5 Gloss pitted rock	4002660
100	Shale 3/4" - grey, black 0.5lb ea	4004792
101	Split Wood Kit	1700SWK
102	Splinters grey, bagged	4005813
103	Small embers, bagged	4006134
104	Split Wood Logs	4006196
	Log #1	4006122
	Log #2	4006123
	Log #3	4006124
	Log #4	4006125
	Log #5	4006126
	Log #6	4006127
	Log #7	4006128
	Log #8	4006129
	Log #9	4006130
	Log #10	4006131
	Log #11	4006132
105	Birch Log Kit	1700BLK
	Log L1	4007371
	Log L2	4007372
	Log L3	4007373
	Log L4	4007374
	Log L5	4007375
	Log L6	4007376
	Log L8	4007378
	Log L9	4007379
	Log L12	4007382
106	Mixed grey embers, 8 cup bag	4008046
107	Splinters grey, bagged	4005813
108	GV60 Valve Repair Kit	4004544

# Appendix E - Spare Parts

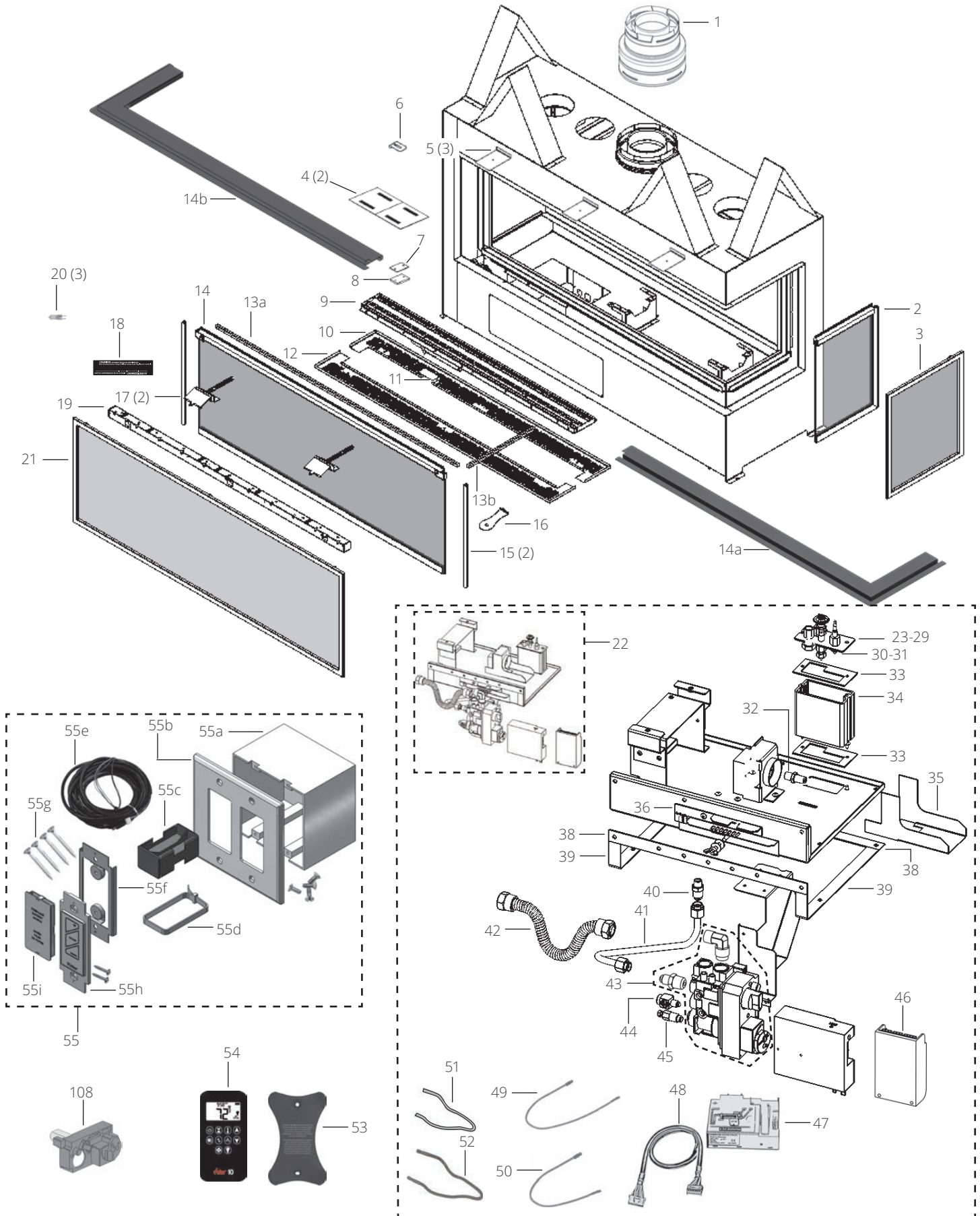

# Appendix E - Spare Parts

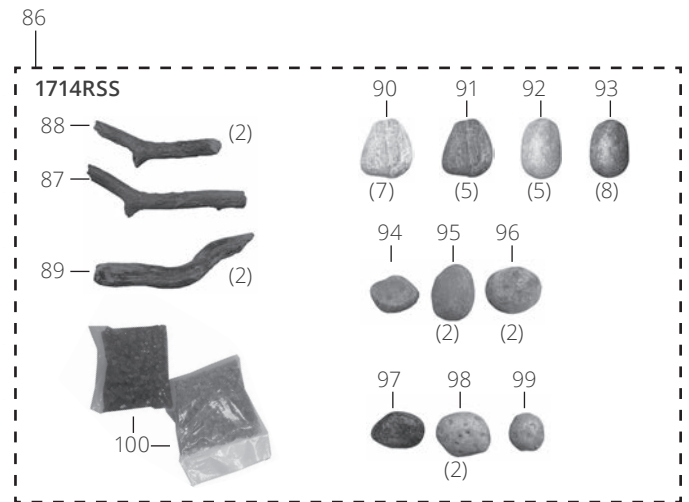
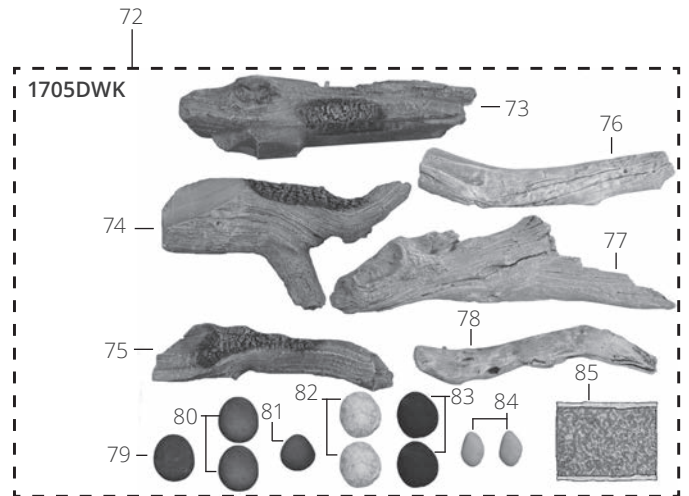
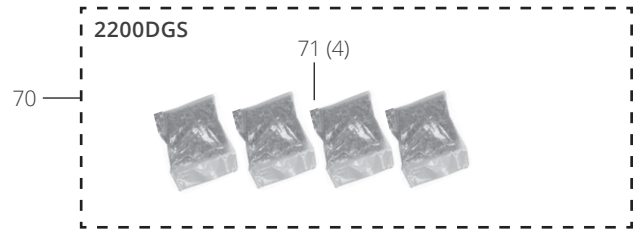
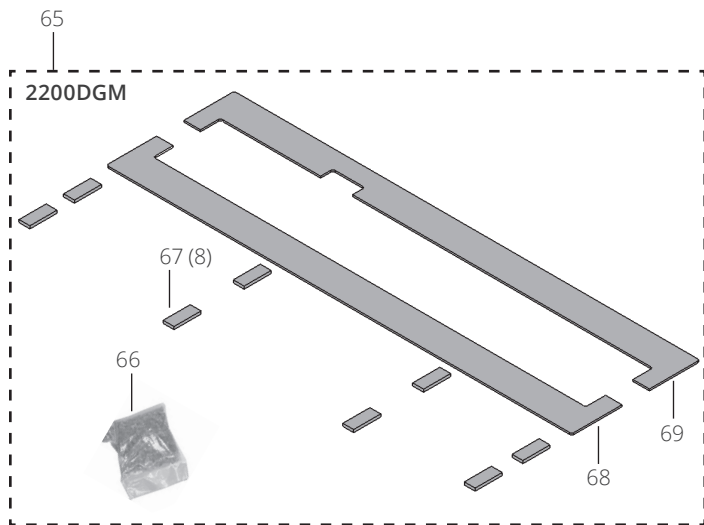
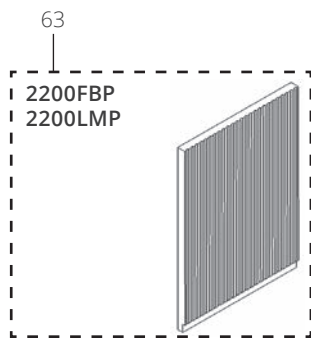
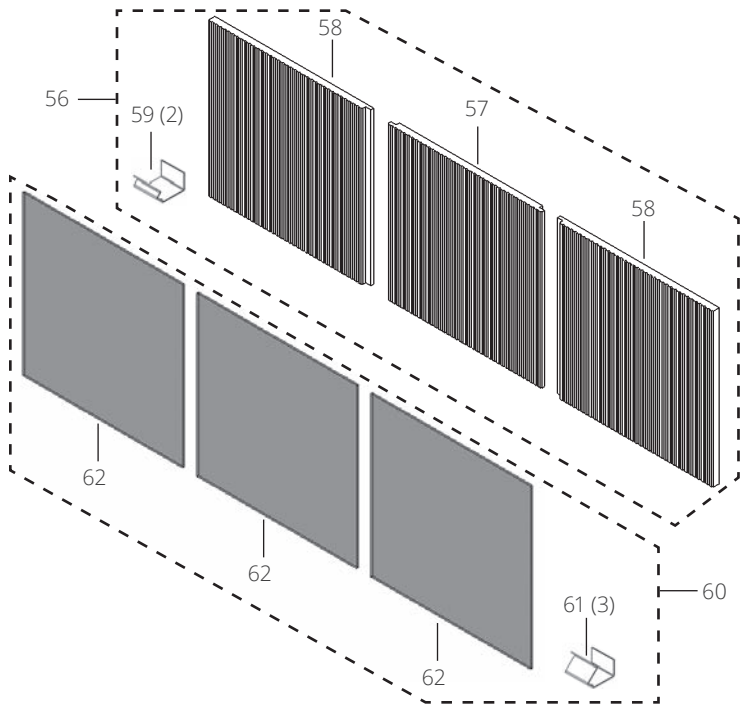

# Appendix E - Spare Parts

